

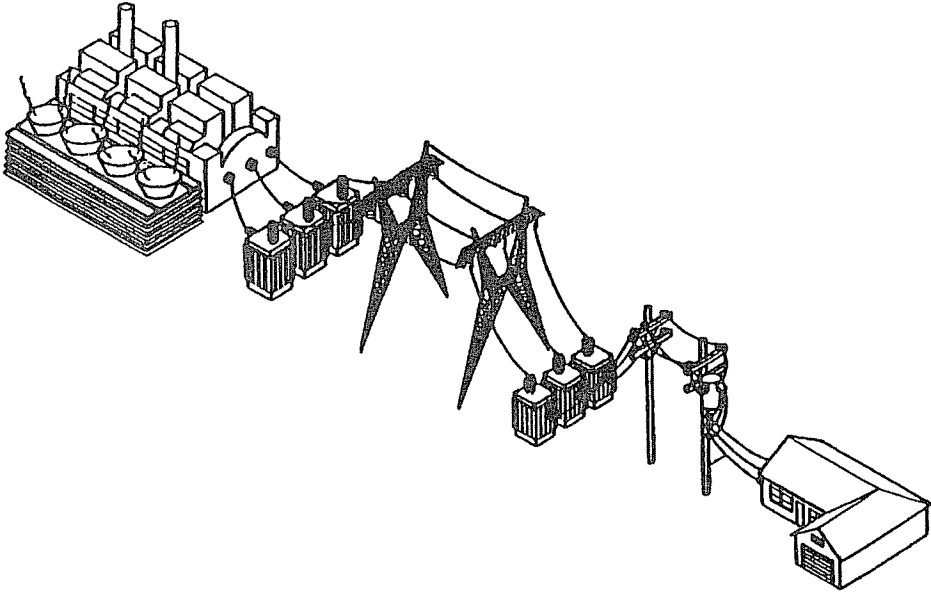

# BASIC ELECTRICAL SAFETY



(

(

(



## **PREFACE**

The concepts discussed herein are intended to provide explanation and clarification of basic electrical safety for individuals who have little or limited training or familiarity with the field of electricity.

An understanding of these principles is essential for comprehension of OSHA's Electrical Safety Standards.

(

(

(



## **TABLE OF CONTENTS**

<u>TOPIC</u>	<u>PAGE</u>
Theory of Electricity .....	1
Hazards of Electricity .....	25
Effects of Electricity on the Human Body .....	28
Common Workplace Circuits .....	33
Electrical Protective Devices .....	35
Grounding .....	40
Ground Fault Circuit Interrupters .....	46
Reversed Polarity .....	51
Glossary .....	58





## THEORY OF ELECTRICITY

### What is Electricity?

Though you cannot see electricity, you are aware of it every day. You see it used in countless ways. You cannot taste or smell electricity, but you can feel it.

Basically, there are two kinds of electricity - static (stationary) and dynamic (moving). This module is about dynamic electricity because that is the kind commonly put to use.

Electricity (dynamic) is characterized by the *flow of electrons through a conductor*. To understand this phenomenon, you must know something about chemical elements and atoms.

### Elements and Atoms

Elements are the most basic of materials. Every known substance - solid, liquid, or gas - is composed of elements.

An atom is the smallest particle of an element that retains all the properties of that element. Each element has its own kind of atom; i.e., all hydrogen atoms are alike, and they are all different from the atoms of other elements. However, all atoms have certain things in common. They all have an inner part, the nucleus, composed of tiny particles called protons and neutrons. An atom also has an outer part. It consists of other tiny particles, called electrons, which orbit around the nucleus. Neutrons have no electrical charge, but protons are positively charged. Electrons have a negative charge. The atoms of each element have a definite number of electrons, and they have the same number



of protons. An aluminum atom, for example, has thirteen of each. The opposite charges - negative electrons and positive protons - attract each other and tend to hold electrons in orbit. As long as this arrangement is not changed, an atom is electrically balanced. This is illustrated in the figure below.

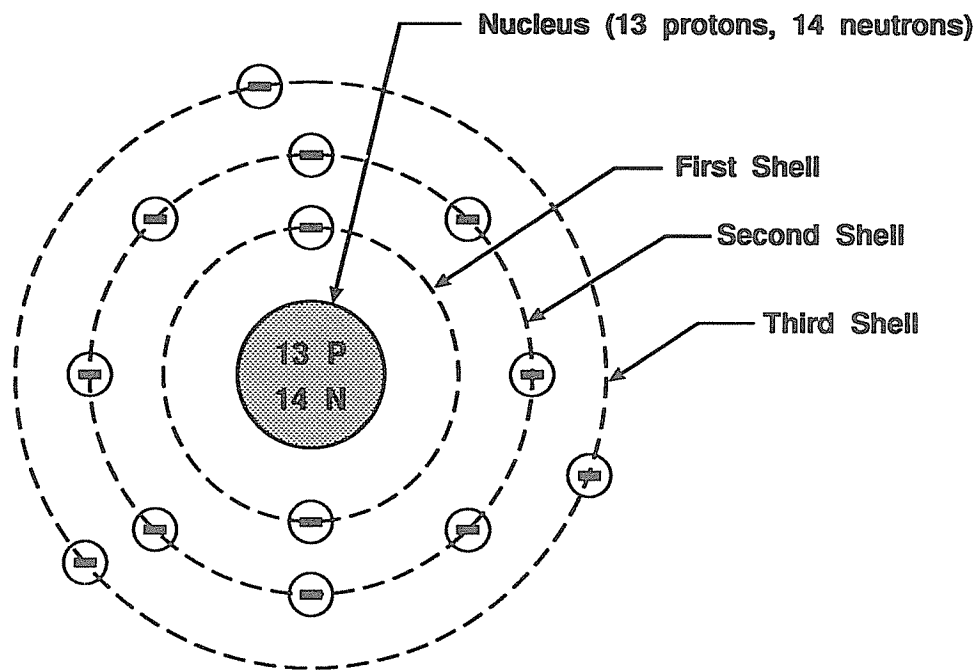

ALUMINUM ATOM

However, the electrons of some atoms are easily moved out of their orbits. This ability of electrons to move or flow is the basis of current electricity.

When electrons leave their orbits, they are referred to as free electrons. If the movement of free electrons is channeled in a given direction, a flow of electrons occurs. As previously stated, the flow of electrons through a conductor characterizes dynamic electricity.





## Electrical Materials

A material that contains many free electrons and is capable of carrying an electric current is called a conductor. Metals and (generally) water are conductors. Gold, silver, aluminum and copper are all good conductors.

Materials that contain relatively few free electrons are called insulators. Non-metallic materials such as wood, rubber, glass and mica are insulators.

Fair conductors include the human body, earth, and concrete.

## Generating Electricity

There are several ways to produce electricity. Friction, pressure, heat, light, chemical action, and magnetism are among the more practical methods used to make electrons move along a conductor.

To date, magnetism is the most inexpensive way of producing electrical power and is therefore of most interest to us. Because of the interaction of electricity and magnetism, electricity can be generated economically and abundantly and electric motors can be used to drive machinery. Electricity is produced when a magnet is moved past a piece of wire. Or, a piece of wire can be moved through a magnetic field. A magnetic field, motion, and a piece of wire are needed to produce electricity.

## Voltage, Current and Resistance

### Voltage

A force or pressure must be present before water will flow through a pipeline. Similarly, electrons flow through a conductor because a force called electromotive force (EMF) is exerted. The unit of measure for EMF is the volt.



The symbol for voltage is the letter E. A voltmeter is used to measure voltage.

### Current

For electrons to move in a particular direction, it is necessary for a potential difference to exist between two points of the EMF source. The continuous movement of electrons past a given point is known as current. It is measured in amperes. The symbol for current is the letter I and for amperes, the letter A. It is sometimes necessary to use smaller units of measurement. The milliampere (mA) is used to indicate 1/1000 (0.001) of an ampere. If an even smaller unit is needed, it is usually the microampere ( $\mu\text{A}$ ). The microampere is one-millionth of an ampere.

An ammeter is used to measure current in amperes. A microammeter or a milliammeter may be used to measure smaller units of current.

### Resistance

The movement of electrons along a conductor meets with some opposition. This opposition is known as resistance. Resistance can be useful in electrical work. Resistance makes it possible to generate heat, control current flow, and supply the correct voltage to a device. The symbol for resistance is shown in the accompanying figure.



In general, resistance in a conductor depends on four factors: the *material* from which it is made, the *length*, the *cross-sectional area*, and the *temperature* of the material.

- *Material.* Different materials have different resistances. Some, such as silver and copper, have a low resistance, while others, such as iron have a higher resistance.



- *Length.* For a given material that has a constant cross-sectional area, the total resistance is *proportional* to the length. The longer the conductor, the greater the resistance.
- *Cross-Sectional Area.* Resistance varies inversely with the cross-sectional area of the conductor. In other words, the resistance *decreases* as the cross-sectional area *increases*.
- *Temperature.* Generally, in metals, the resistance increases as the temperature increases. For non-metals, the reverse is usually true.

The symbol for resistance is the letter R. Resistance is measured by a unit called the ohm. The Greek letter *omega* ( $\Omega$ ) is used as the symbol for electrical resistance.

The figure below summarizes the factors that affect resistance.



## FACTORS THAT AFFECT RESISTANCE

### 1. MATERIAL

In decreasing value of resistance:

- Iron
- Aluminum
- Copper
- Silver

### 2. LENGTH

The longer the conductor, the greater the resistance

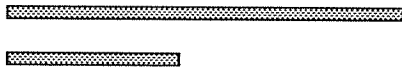

### 3. CROSS-SECTIONAL AREA

The smaller the cross-sectional area, the greater the resistance

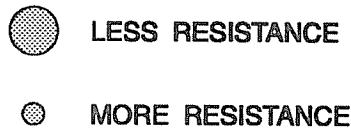

### 4. TEMPERATURE

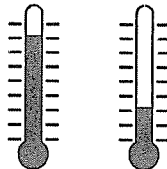

For metals - generally, the higher the temperature,  
the greater the resistance

For non-metals - usually the reverse!



## Direct Current (dc) Circuits

### Introduction

This section discusses the electrical relationships in direct-current circuits. Although alternating current is more commonly used in electrical work, direct current has its own unique applications and advantages. Direct current always flows in one direction.

Some dc motors, for example, have speed control characteristics that are better in some production operations. Direct current is used to charge storage batteries, for plating operations, for aluminum refining, and to operate electromagnetic lifting devices and most welding equipment.

### Complete Circuit

A complete circuit is necessary for the controlled flow or movement of electrons along a conductor. A complete circuit is made up of a source of electricity (e.g., battery), a conductor, and a consuming device (load). This is illustrated in the figure below.

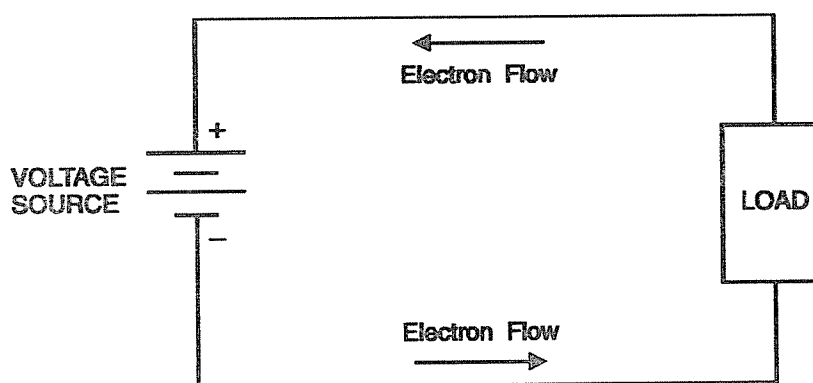

**SIMPLE CIRCUIT**



The orientation of the positive (+) and negative (-) terminals of the battery remains constant. Since this voltage polarity does not change, the electrons flow in one direction. The negatively charged electrons flow away from the (-) terminal of the voltage source and toward the (+) terminal of the voltage source. By convention, the direction of current flow is the direction in which positive electricity would move to cause the same effects as are produced by the actual motion of electricity. Therefore, the direction of current, as it is usually considered, is in the opposite direction to the motion of the electrons.

The movement of the electrons along the completed path provides energy. If the circuit is so arranged that the electrons have only one path, the circuit is called a *series circuit*. If there are two or more paths for electrons, the circuit is called a *parallel circuit*.

### Series Circuit

The figure below shows three loads (resistors) connected in series. The current flows through each of them before returning to the battery.

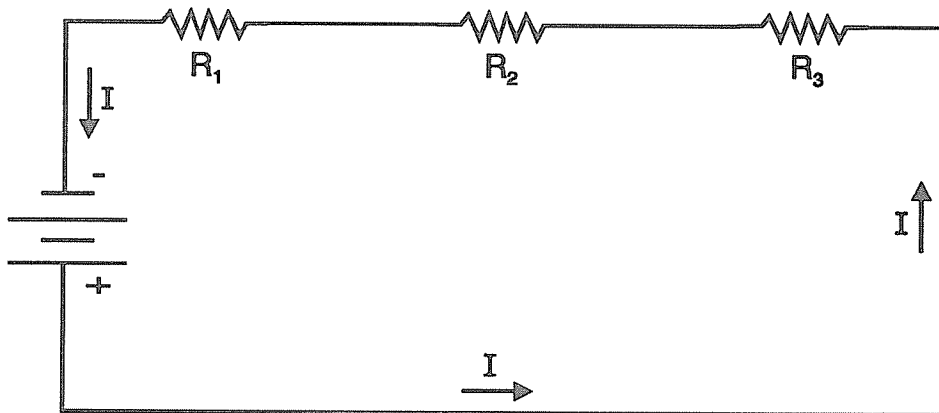

**SERIES CIRCUIT**



To find the total resistance in a series circuit, just add the individual resistances:

$$R_T = R_1 + R_2 + R_3 + \dots$$

### Parallel Circuit

In a parallel circuit, each load is connected directly across the voltage source. There are as many separate paths for current flow as there are branches. See figure below.

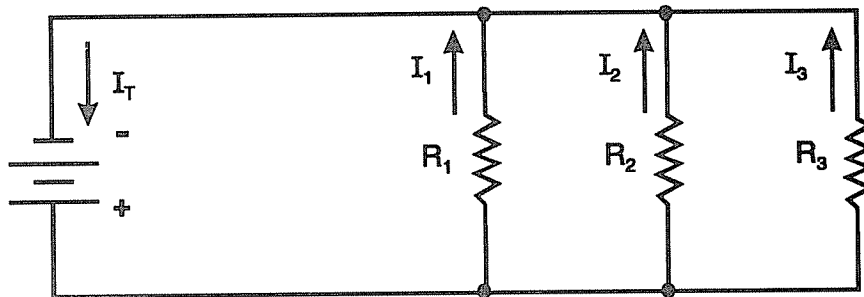

**PARALLEL CIRCUIT**

The voltage across all branches of a parallel circuit is the same. This is because all branches are connected across the voltage source. Current in a parallel circuit depends on the resistance of the branch. *Ohm's Law* (discussed later) can be used to determine the current in each branch. You can find the total current by adding the individual currents. Expressed as a formula:

$$I_T = I_1 + I_2 + I_3 + \dots$$



The total resistance of a parallel circuit *cannot* be found by adding the resistor values. The following formula can be used to determine the total resistance in a parallel circuit:

$$\frac{1}{R_T} = \frac{1}{R_1} + \frac{1}{R_2} + \frac{1}{R_3} + \dots$$

One thing to keep in mind for parallel resistances:

*The total resistance is always less than the smallest resistance.*

### Series-Parallel Circuits

Series-parallel circuits are a combination of the two circuits. The figure below shows a series-parallel resistance circuit.

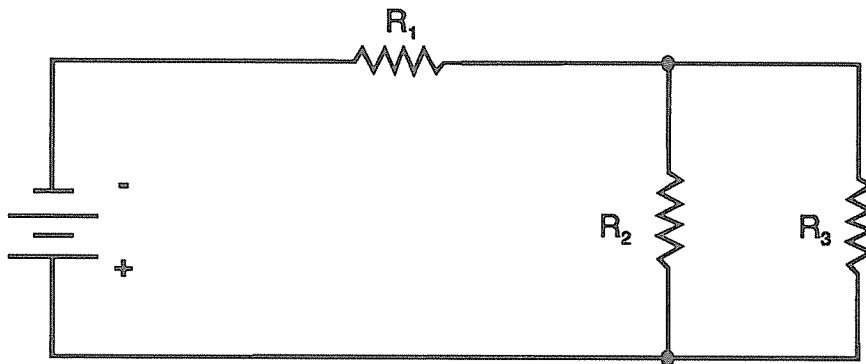

**SERIES-PARALLEL CIRCUIT**





### Open Circuit

An open circuit is one which does not have a complete path for electrons to follow. Therefore, there is no current flow. Such an incomplete path is usually brought about by a loose connection or the opening of a switch. An open circuit caused by an open switch is illustrated in the figure below.

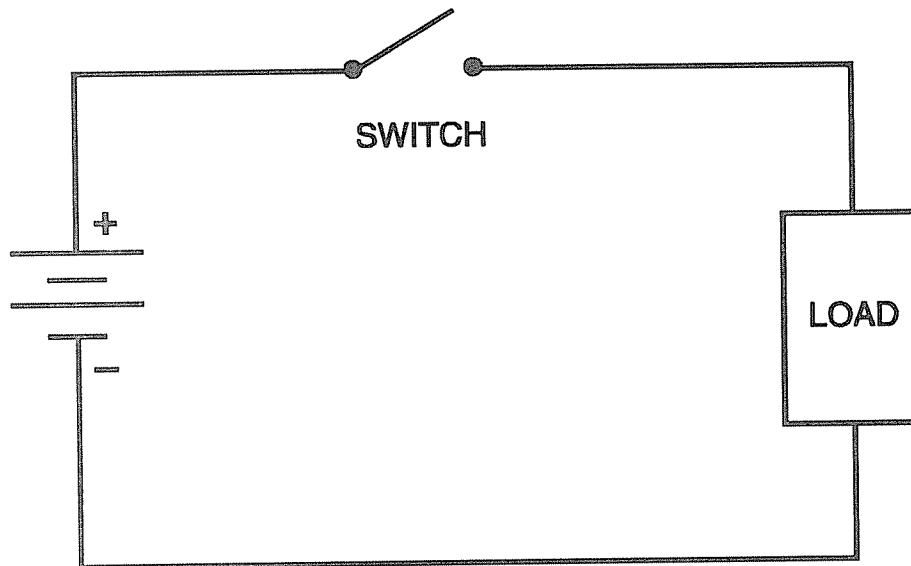

**OPEN CIRCUIT**

### Short Circuit

A short circuit is one which has a path of low resistance to electron flow. It is usually created when a low-resistance wire is placed across a consuming device. A greater number of electrons will flow through the path of least resistance rather than through the consuming device. A short usually generates an excess current flow which results in overheating, possibly causing a fire or other damage. The figure below illustrates a short circuit.

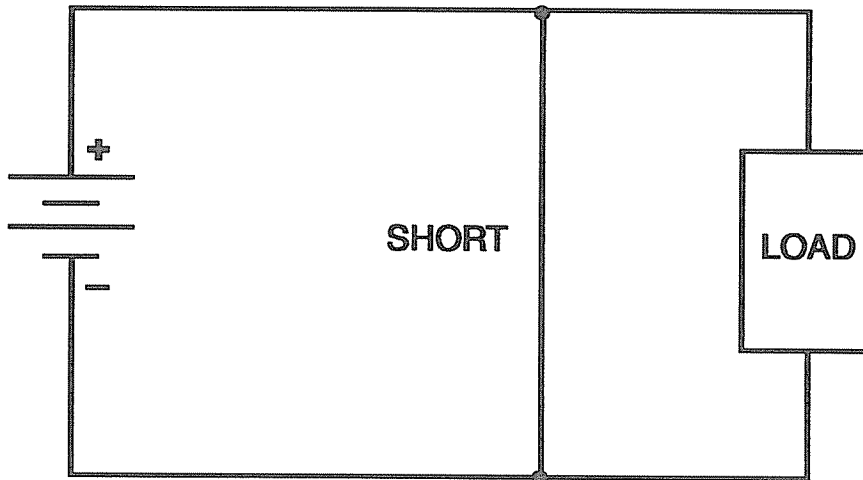

## SHORT CIRCUIT

It is easy to compute the amount of current flowing in a circuit if the voltage and the resistance are known. The relationship between voltage, current, and resistance in any circuit is shown by *Ohm's Law*.



## Ohm's Law

*Ohm's Law* states the relationship that exists among the three basic quantities of electricity: current, voltage, and resistance. A physicist named Georg S. Ohm discovered the relationship in 1827. With this law you can calculate any one of the three quantities if you know the other two. *Ohm's Law* is the most important and most often applied law in electricity. To understand electricity and electrical safety, you must thoroughly understand *Ohm's Law*.

Simply stated, voltage (E) in volts is equal to the current (I) in amperes multiplied by the resistance (R) in ohms. In equation form:

$$E = I R$$

This is the formula to use in order to find the voltage when the current and resistance are known.

To find the current when the voltage and resistance are known, the formula becomes:

$$I = \frac{E}{R}$$

To find the resistance when the voltage and current are known, the formula becomes:

$$R = \frac{E}{I}$$



The best way to become accustomed to using *Ohm's Law* is to solve some basic problems, such as:

1. If the current is 5 amps and the resistance is 20 ohms, what is the applied voltage?

$$E = I R$$

$$E = (5)(20)$$

$$E = 100 \text{ volts}$$

2. If the voltage is 100 volts and the resistance is 25 ohms, what is the current in the circuit?

$$I = \frac{E}{R}$$

$$I = \frac{100}{25}$$

$$I = 4 \text{ amps}$$

3. If the current is 2 amps and the applied voltage is 100 volts, what is the resistance?

$$R = \frac{E}{I}$$

$$R = \frac{100}{2}$$

$$R = 50 \text{ ohms}$$



## Power

Power is defined as the rate of doing work. It is expressed in metric measurements in watts. Power formulas are sometimes needed to figure the voltage of a circuit. The three most commonly used formulas are:

$$P = E I$$

$$P = \frac{E^2}{R}$$

$$P = I^2 R$$

Similar to the application of *Ohm's Law*, you can calculate any one of the three quantities if you know the other two. Later in this module, we will discuss the problem of " $I^2 R$ " losses.



## Alternating Current (ac) Circuits

### Comparison of ac and dc

Direct current flows continuously in one direction through a circuit because the polarity of the voltage source never changes. But alternating current changes rapidly in both direction and value. In an ac circuit, current flows from the positive terminal to the negative terminal, just as in a dc circuit. But the polarity of the ac terminals reverses at regular intervals, causing the direction of current flow to also reverse.

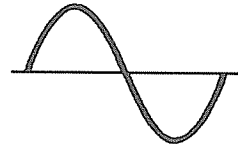

### Advantages of Alternating Current

Power companies use ac generators, also called alternators, to produce electrical power more economically than was previously possible with dc generators. The main reason for this is that the power lost during the transmission of ac from the generating station to the user is very much less than with dc. Using ac, the power companies are able to "transform" the produced electrical energy into a high-voltage, but low-current, equivalent power. The device used to conveniently raise or lower the voltage is called a *transformer*.

Conductors, or transmission lines, transport electrical power. All conductors have some amount of resistance. Although the amount of resistance for a one foot length of conductor may be small, this resistance is placed in series with each foot of a transmission line, which can be hundreds of miles long. Over these long distances, the power losses, as given by  $P=I^2 R$ , can become excessive due to the resistance of the transmission lines.

With dc, load governs the current flowing in the line; i.e., the current may be zero if there is no demand, or very high if there is a large demand. The only way to reduce power losses in this situation is to try to lower the resistance of the transmission lines.



Note, however, that even if the resistance could be cut in half, the power loss would also be only halved, as shown by  $P=I^2R$ . But because power is proportional to the *square* of the current, reducing the current by half reduces the power loss by *four times*. Another power formula,  $P=EI$ , tells us that we could indeed cut the current in half by doubling the voltage, and still transmit the same amount of power.

Powerful transformers operating on the principle of *mutual induction* can boost the voltage in accordance with these requirements. A transformer consists of two coils of wire wound on the same core. The input voltage is applied to one coil, called the *primary*, and the voltage output is taken from the other coil, called the *secondary*. When the secondary has twice as many turns of wire as the primary, the transformer has a *turns ratio* of 2:1. The rising and falling magnetic field in the primary coil cuts across twice as many conductors in the secondary, and the transformer is called a *step-up* transformer. By reversing this procedure, the original voltage can be obtained using a *step-down* transformer. The symbol for a transformer is shown in the accompanying figure.

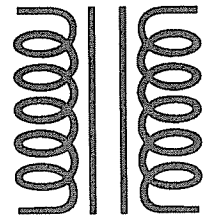

Transformers perform two functions in the transmission of ac. They step up and step down the voltage, and they isolate the generating station from the load. In this way, power companies can maintain low current levels in the transmission lines, and hold power losses to a minimum. The figure below represents the common means of generating, transmitting, and distributing electric power.



# ELECTRIC POWER GENERATION, TRANSMISSION AND DISTRIBUTION

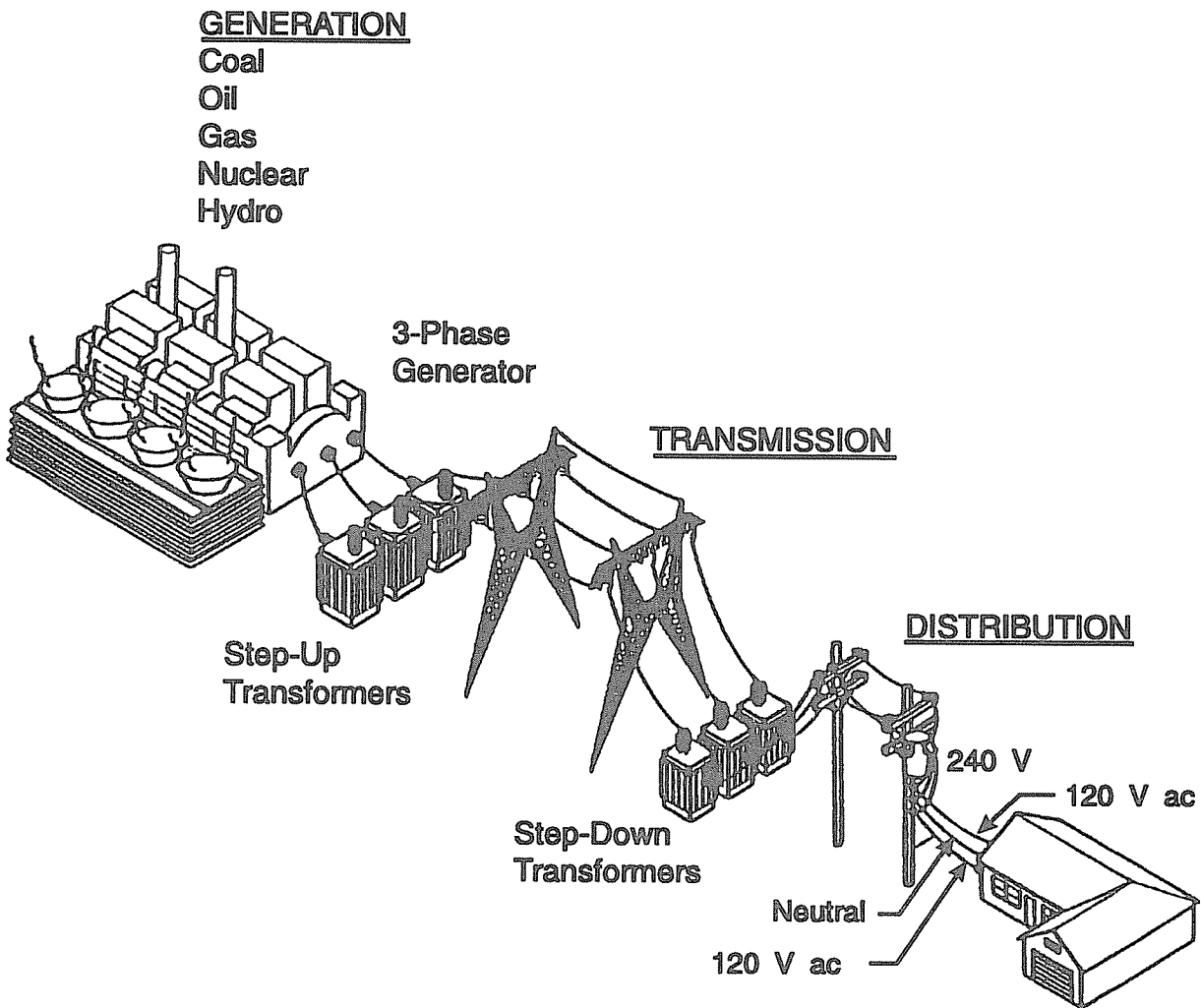





### Electromagnetism

The first indication of a relationship between magnetism and electricity was discovered by Hans Christian Oersted in 1820. He connected a wire between the two terminals of a battery and held the wire over a magnetic compass needle. When the wire was held parallel to the compass needle, the needle deflected from its normal position.

When current flows through a conductor, a magnetic field is formed *outside* of the conductor. The current direction determines the direction of the magnetic field. This is illustrated in the figure below.

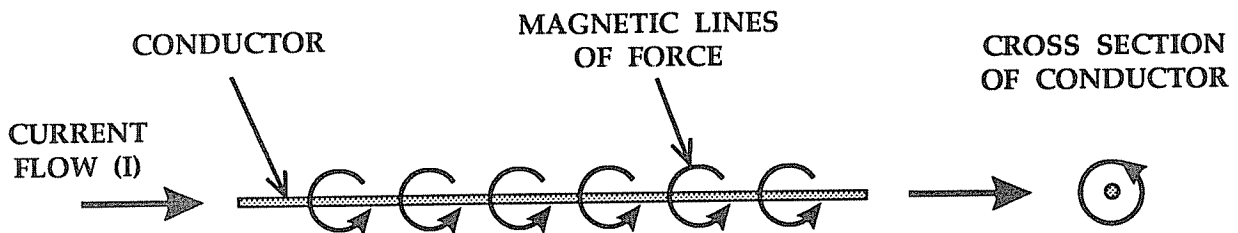

### Inductance

Inductance is the property of an electric circuit by virtue of which a varying current induces an electromotive force in that circuit or in a neighboring circuit. We know from our previous discussion that magnetic lines of force surround the outside of a conductor when current flows. With an ac circuit, the voltage is constantly changing direction and the magnetic lines of force are constantly moving in and out from the conductor. In any conductor, an expanding or collapsing magnetic field will cut across the conductor and induce a voltage in the conductor that opposes the applied voltage. The symbol for inductance is shown in the accompanying figure.

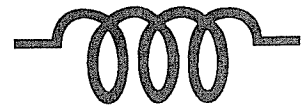



### Inductive Reactance

The opposition to current flow in a circuit due to inductance is called *inductive reactance*. The symbol for inductive reactance is  $X_L$  and it is measured in ohms.

### Capacitance

Capacitance is the property of an electric circuit that opposes any change of voltage. When the applied ac voltage increases, capacitance opposes the change and delays the voltage increase across the circuit. When the applied voltage decreases, capacitance tends to maintain the original voltage across the circuit and delays the decrease in voltage. The symbol for capacitance is shown in the accompanying figure.

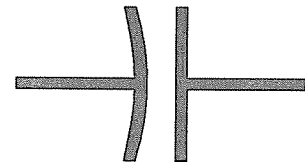

### Capacitive Reactance

The opposition to current flow in a circuit due to capacitance is called *capacitive reactance*. The symbol for capacitive reactance is  $X_C$  and it is measured in ohms.

### Impedance

We have shown that resistance is a characteristic of electrical conductors which tends to hold back or impede the flow of current. This effect can be visualized as friction inside of the conductor. Friction requires force to overcome it; just as friction makes it difficult to push a heavy box along a concrete floor. And in each case, the friction produces heat.

In addition to overcoming resistance (friction) *inside* of a conductor, the current may also encounter some impedance cause by something *outside* of the conductor. That something is called "magnetic reactance," because it is a magnetic effect reacting against the current which caused it. Alternating current is constantly forcing this magnetic field to change, and this is a burden imposed on the current.



Inductive reactance ( $X_L$ ) and capacitive reactance ( $X_C$ ) can be combined to yield the total "magnetic reactance" ( $X$ ). In equation form:

$$X = X_L - X_C$$

Resistance and reactance combine to form the total opposition to current flow in ac systems, known as *impedance*. The symbol for impedance is Z and, like resistance and reactance, it is measured in ohms.

The table below provides a summary of the meaning and use of the electrical terms that we have discussed up to this point.

SUMMARY OF ELECTRICAL TERMS				
FUNCTION	TERM	SYMBOL	UNIT OF MEASURE	ABBREVIATION
Force	Voltage	E	Voltage	V
Result of Force	Current	I	Ampere	A
Resists Current Flow Due to Physical Properties	Resistance	R	Ohm	$\Omega$
Resists Current Flow Due to Magnetic Effect	Reactance	X	Ohm	$\Omega$
Total Opposition to Current Flow in ac Systems	Impedance	Z	Ohm	$\Omega$



## Extending Ohm's Law to ac Circuits

Since "magnetic reactance" helps the resistance in holding back the flow of current, we must amend *Ohm's Law* to show the influence of both of these factors.

If resistance (R) and reactance (X) are correctly added, we call the sum impedance (Z), and represent it thus:

$$Z = \sqrt{R^2 + X^2}$$

*Ohm's Law* for ac circuits then becomes:

$$I = \frac{E}{Z}$$

The importance of the distinction between "R" and "Z" will become apparent when we discuss how overcurrent and grounding protection are supposed to protect against electrical accidents.

## Low Impedance Circuit

The concepts we have discussed so far are of primary importance to understanding electrical safety. Although the details of this will be discussed later, it seems appropriate at this time to discuss the concept of a low impedance circuit.

The figure below should aid in this discussion.



## LOW IMPEDANCE CIRCUIT

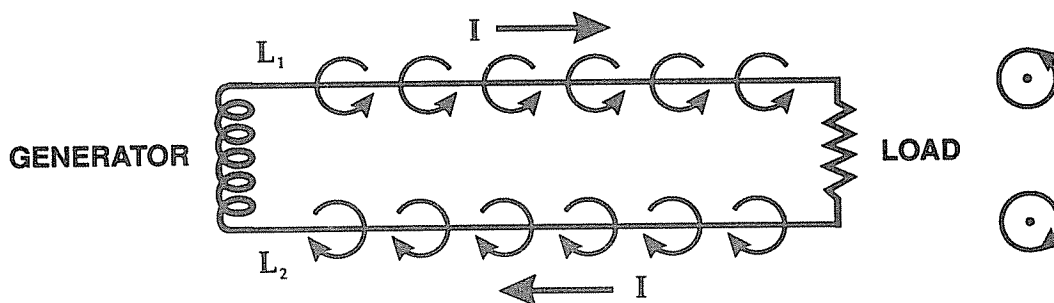

In a conventional circuit, the current flowing in the RETURNING line produces a field which is equal and opposite to the field produced by the OUTGOING line.

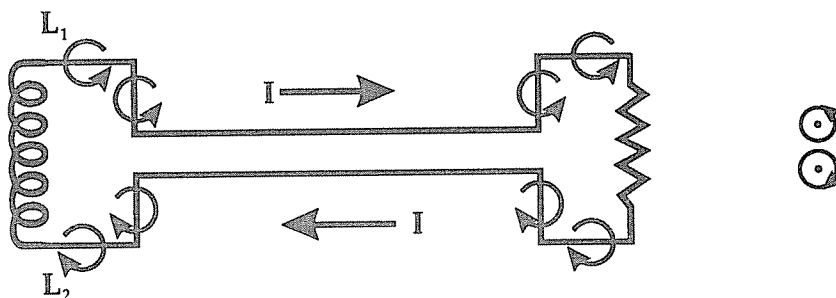

If the outgoing and returning conductors of a current loop are close together, the two magnetic fields CANCEL EACH OTHER. The "magnetic reactance" is then close to zero for that portion of the loop.



In a conventional circuit, the current flowing in the returning line produces a magnetic flux which is equal and opposite to the field produced by the outgoing line. The various loads on a circuit are combined into one symbol as though it were all one resistance. The source of current is represented as a coil of a generator. A coil drawn like this may also represent a transformer.

If the outgoing and returning conductors of a circuit are close together, the two magnetic fields cancel each other. The magnetic reactance is then close to zero for that part of the circuit. *It is vitally important that you understand this point.* There are many electrical circuits that are hazardous because a return conductor for ground fault current is not close to the supply conductor. We will learn why this is a hazard later in this module.



## HAZARDS OF ELECTRICITY

The primary hazards associated with electricity and its use are:

- **SHOCK.** Electric shock occurs when the human body becomes part of a path through which electrons can flow. The resulting effect on the body can be either *direct* or *indirect*.
  - **Direct.** Injury or death can occur whenever electric current flows through the human body. Currents of less than 30 mA can result in death. A thorough coverage of the effects of electricity on the human body is contained in the section of this module entitled *Effects of Electricity on the Human Body*.
  - **Indirect.** Although the electric current through the human body may be well below the values required to cause noticeable injury, human reaction can result in falls from ladders or scaffolds, or movement into operating machinery. Such reaction can result in serious injury or death.
- **BURNS.** Burns can result when a person touches electrical wiring or equipment that is improperly used or maintained. Typically, such burn injuries occur on the hands.
- **ARC-BLAST.** Arc-blasts occur from high-amperage currents arcing through air. This abnormal current flow (arc-blast) is initiated by contact between two energized points. This contact can be caused by persons who have an accident while working on energized components, or by equipment failure due to fatigue or abuse. Temperatures as high as 35,000°F have been recorded in arc-blast research. The three primary hazards associated with an arc-blast are:



- **Thermal Radiation.** In most cases, the radiated thermal energy is only part of the total energy available from the arc. Numerous factors, including skin color, area of skin exposed, type of clothing have an effect on the degree of injury. Proper clothing, work distances and overcurrent protection can improve the chances of curable burns.
  
- **Pressure Wave.** A high-energy arcing fault can produce a considerable pressure wave. Research has shown that a person 2 feet away from a 25 kA arc would experience a force of approximately 480 pounds on the front of their body. In addition, such a pressure wave can cause serious ear damage and memory loss due to mild concussions.

In some instances, the pressure wave may propel the victim away from the arc-blast, reducing the exposure to the thermal energy. However, such rapid movement could also cause serious physical injury.

- **Projectiles.** The pressure wave can propel relatively large objects over a considerable distance. In some cases, the pressure wave has sufficient force to snap the heads of 3/8 inch steel bolts and knock over ordinary construction walls.

The high-energy arc also causes many of the copper and aluminum components in the electrical equipment to become molten. These "droplets" of molten metal can be propelled great distances by the pressure wave. Although these droplets cool rapidly, they can still be above temperatures capable of causing serious burns or igniting ordinary clothing at distances of 10 feet or more. In many cases, the burning effect is much worse than the injury from shrapnel effects of the droplets.





- **EXPLOSIONS.** Explosions occur when electricity provides a source of ignition for an explosive mixture in the atmosphere. Ignition can be due to overheated conductors or equipment, or normal arcing (sparking) at switch contacts. OSHA standards, the National Electrical Code and related safety standards have precise requirements for electrical systems and equipment when applied in such areas.
- **FIRES.** Electricity is one of the most common causes of fire both in the home and workplace. Defective or misused electrical equipment is a major cause, with high resistance connections being one of the primary sources of ignition. High resistance connections occur where wires are improperly spliced or connected to other components such as receptacle outlets and switches. This was the primary cause of fires associated with the use of aluminum wire in buildings during the 1960s and 1970s.

Heat is developed in an electrical conductor by the flow of current at the rate  $I^2R$ . The heat thus released elevates the temperature of the conductor material. A typical use of this formula illustrates a common electrical hazard. If there is a bad connection at a receptacle, resulting in a resistance of 2 ohms, and a current of 10 amperes flows through that resistance, the rate of heat produced (W) would be:

$$W = I^2R = 10^2 \times 2 = 200 \text{ watts}$$

If you have ever touched an energized 200 watt light bulb, you will realize that this is a lot of heat to be concentrated in the confined space of a receptacle. Situations similar to this can contribute to electrical fires.



## EFFECTS OF ELECTRICITY ON THE HUMAN BODY

The effects of electric shock on the human body depend on several factors. The major factors are:

1. Current and Voltage
2. Resistance
3. Path through body
4. Duration of shock

The muscular structure of the body is also a factor in that people having less musculature and more fat typically show similar effects at lesser current values.

### Current and Voltage

Although high voltage often produces massive destruction of tissue at contact locations, it is generally believed that the detrimental effects of electric shock are due to the *current* actually flowing through the body. Even though Ohm's law ( $I=E/R$ ) applies, it is often difficult to correlate voltage with damage to the body because of the large variations in contact resistance usually present in accidents. Any electrical device used on a house wiring circuit can, under certain conditions, transmit a fatal current. Although currents greater than 10 mA are capable of producing painful to severe shock, currents between 100 and 200 mA can be lethal.

With increasing alternating current, the sensations of tingling give way to contractions of the muscles. The muscular contractions and accompanying sensations of heat increase as the current is increased. Sensations of pain develop, and voluntary control of the muscles that lie in the current pathway becomes increasingly difficult. As current approaches 15 mA, the victim cannot let go of the conductive surface being grasped. At this point, the individual is



said to "freeze" to the circuit. This is frequently referred to as the "let-go" threshold.

As current approaches 100 mA, ventricular fibrillation of the heart occurs. Ventricular fibrillation is defined as "very rapid uncoordinated contractions of the ventricles of the heart resulting in loss of synchronization between heartbeat and pulse beat." Once ventricular fibrillation occurs, it will continue and death will ensue within a few minutes. Use of a special device called a de-fibrillator is required to save the victim.

Heavy current flow can result in severe burns and heart paralysis. If shock is of short duration, the heart stops during current passage and usually re-starts normally on current interruption, improving the victim's chances for survival.

### Resistance

Studies have shown that the electrical resistance of the human body varies with the amount of moisture on the skin, the pressure applied to the contact point, and the contact area.

The outer layer of skin, the epidermis, has very high resistance when dry. Wet conditions, a cut or other break in the skin will drastically reduce resistance.

Shock severity increases with an increase in pressure of contact. Also, the larger the contact area, the lower the resistance.

Whatever protection is offered by skin resistance decreases rapidly with increase in voltage. Higher voltages have the capability of "breaking down" the outer layers of the skin, thereby reducing the resistance.



## Path Through Body

The path the current takes through the body affects the degree of injury. A small current that passes from one extremity through the heart to the other extremity is capable of causing severe injury or electrocution. There have been many cases where an arm or leg was almost burned off when the extremity came in contact with electrical current and the current only flowed through a portion of the limb before it went out into the other conductor without going through the trunk of the body. Had the current gone through the trunk of the body, the person would almost surely have been electrocuted.

A large number of serious electrical accidents in industry involve current flow from hands to feet. Since such a path involves both the heart and the lungs, results can be fatal.

## Duration of Shock

The duration of the shock has a great bearing on the final outcome. If the shock is of short duration, it may only be a painful experience for the person.

If the level of current flow reaches the approximate ventricular fibrillation threshold of 100 mA, a shock duration of a few seconds could be fatal. This is not much current when you consider that a small light duty portable electric drill draws about 30 times as much.

At relatively high currents, death is inevitable if the shock is of appreciable duration; however, if the shock is of short duration, and if the heart has not been damaged, interruption of the current may be followed by a spontaneous resumption of its normal rhythmic contractions.



## Summary of Effects

We can sum up the lethal effects of electric current as follows:

- Current flow greater than the "let-go" threshold of an individual may cause a person to collapse, become unconscious and can result in death. The current flow would most often have to continue for longer than five seconds. Although it may not be possible to determine the exact cause of death with certainty, asphyxiation or heart failure are the prime suspects.
- Current flow through the chest, neck, head or major nerve centers controlling respiration may result in a failure of the respiratory system. This is usually caused by a disruption of the nerve impulses between the respiratory control center and the respiratory muscles. Such a condition is dangerous since it is possible for the respiratory failure to continue even after the current flow has stopped.
- The most dangerous condition can occur when fairly small amounts of current flow through the heart area. Such current flow can cause ventricular fibrillation. This asynchronous movement of the heart causes the hearts' usual rhythmic pumping action to cease. Death results within minutes.
- When relatively large currents flow through the heart area, heart action may be stopped entirely. If the shock duration is short and no physical damage to the heart has occurred, the heart may begin rhythmic pumping automatically when the current ceases.



- Extensive tissue damage, including internal organ damage due to high temperatures, occurs when very large currents flow through major portions of the body.
- There are recorded cases of delayed death after a person has been revived following an electrical shock. This may occur within minutes, hours or even days after the event has occurred. Several assumptions for such delayed effects are:
  - internal or unseen hemorrhaging
  - emotional or psychological effects of the shock
  - aggravation of a pre-existing condition

In many accidents, there is a combination of the above effects, or additional effects may develop after the initial accident, thus making an accurate diagnosis quite difficult.



## COMMON WORKPLACE CIRCUITS

Following are simplified descriptions of typical circuits to which workers are most commonly exposed.

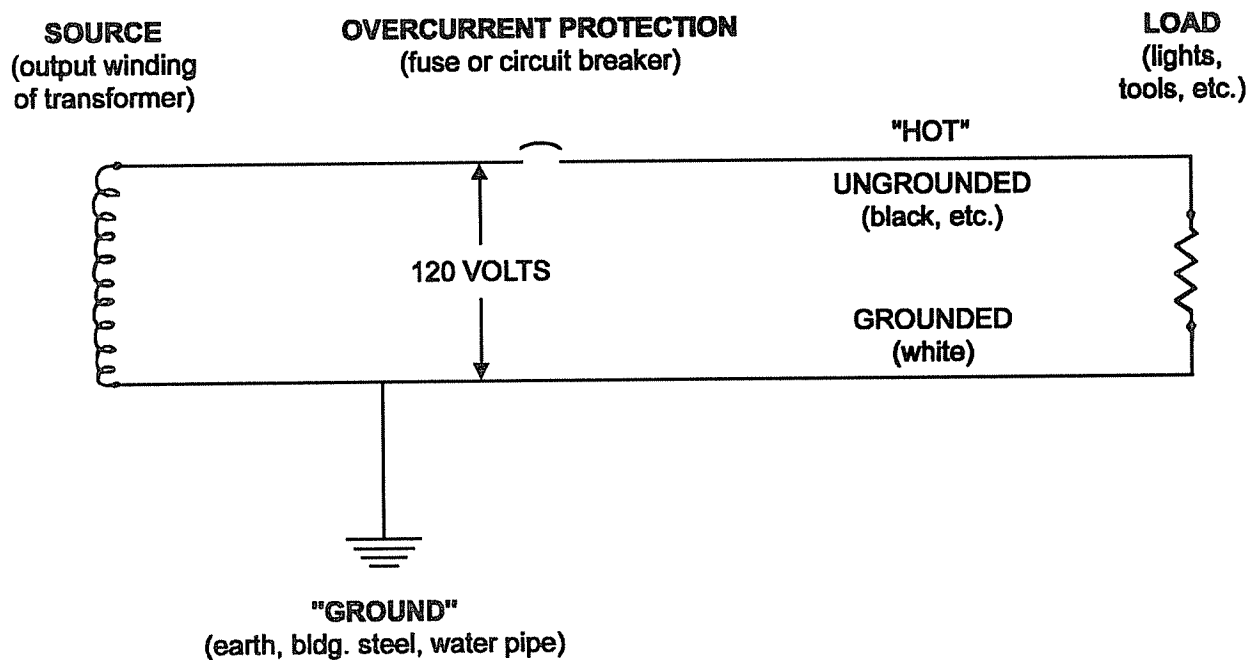

**SINGLE-PHASE 2-WIRE CIRCUIT**  
(usually supplies 8-10 lights or 4-6 receptacles)

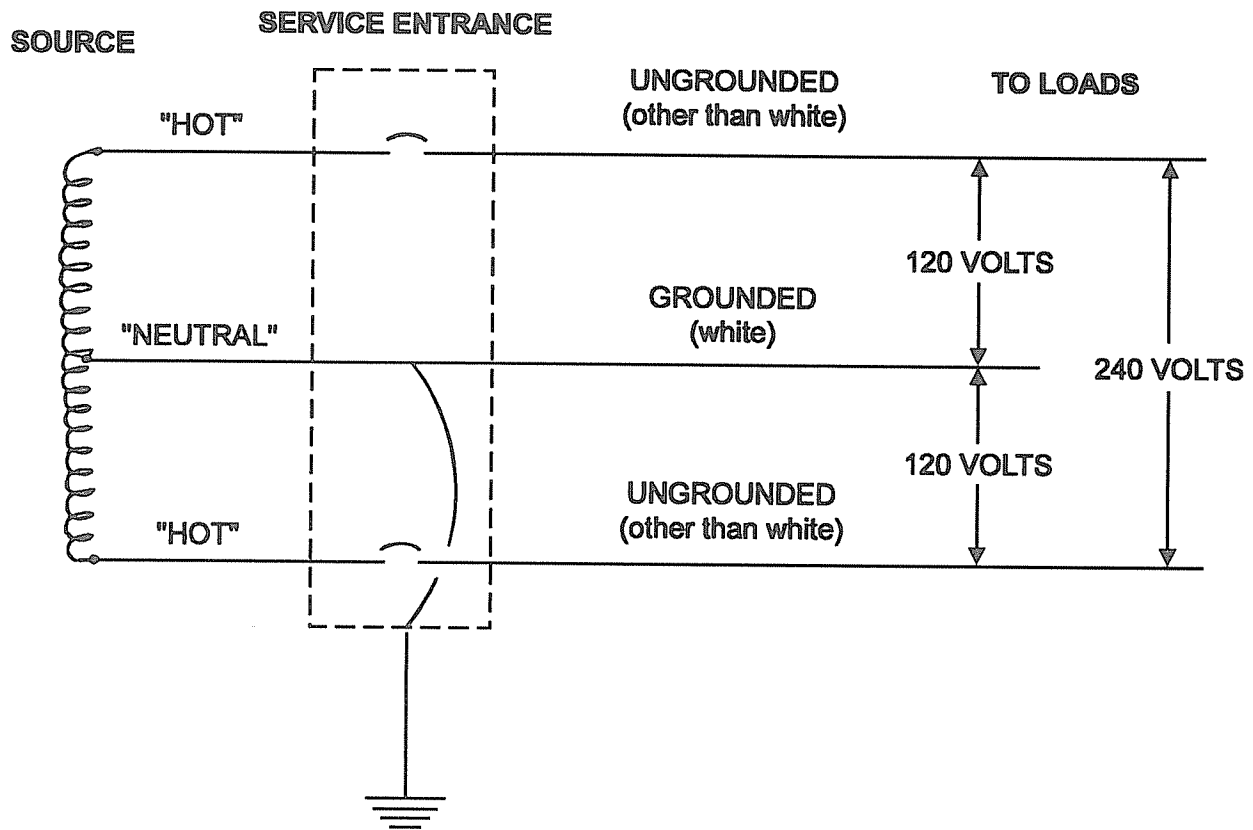

**SINGLE-PHASE 3-WIRE CIRCUIT**

(Usually supplies a number of 2-wire circuits for lights and receptacles, and provides 240 volts for large appliances, as in your home.)





## ELECTRICAL PROTECTIVE DEVICES

### Introduction

As a power source, electricity can create conditions almost certain to result in bodily harm, property damage, or both. It is important for workers to understand the hazards involved when they are working around electrical power tools, maintaining electrical equipment, or installing equipment for electrical operation.

The *electrical protective devices* we will discuss include fuses, circuit breakers, and ground-fault circuit-interrupters (GFCIs). These devices are critically important to electrical safety. *Overcurrent devices* should be installed where required. They should be of the size and type to interrupt current flow when it exceeds the capacity of the conductor. Proper selection takes into account not only the capacity of the conductor, but also the rating of the power supply and potential short circuits.

### Types of Overcurrent

There are two types of overcurrent:

1. Overload - When you ask a 10 hp motor to do the work of a 12 hp motor, an overload condition exists. The overcurrent may be 150 percent of normal current.
2. Fault - When insulation fails in a circuit, fault current can result that may be from 5 times to 50 times that of normal current.

When a circuit is overloaded, the plasticizers in the insulation are vaporized over a long period of time, and the insulation becomes brittle. The brittle



insulation has slightly better electrical insulating properties. However, movement of the conductors due to magnetic or other forces can crack the insulation, and a fault can result. Conductors should be protected from overload and the eventual damage that results.

Faults occur in two ways. Most of the time a fault will occur between a conductor and an enclosure. This is called a *ground fault*. Infrequently, a fault will occur between two conductors. This is called a *short circuit*, and was discussed earlier in this module.

In order to predict what will happen in a normal circuit and a ground-fault circuit, we first need to understand the terminology used to describe electrical systems. The figure below should aid in this discussion. The dashed lines represent the enclosures surrounding the electrical system. These enclosures include the service panel, conduit, and boxes enclosing switches, controllers, equipment terminals, etc. The conduit bonds all of the enclosures together such that there is no electrical potential between them. It also provides an emergency path for ground-fault current to return to the voltage source which in this case is shown as secondary windings of a transformer.

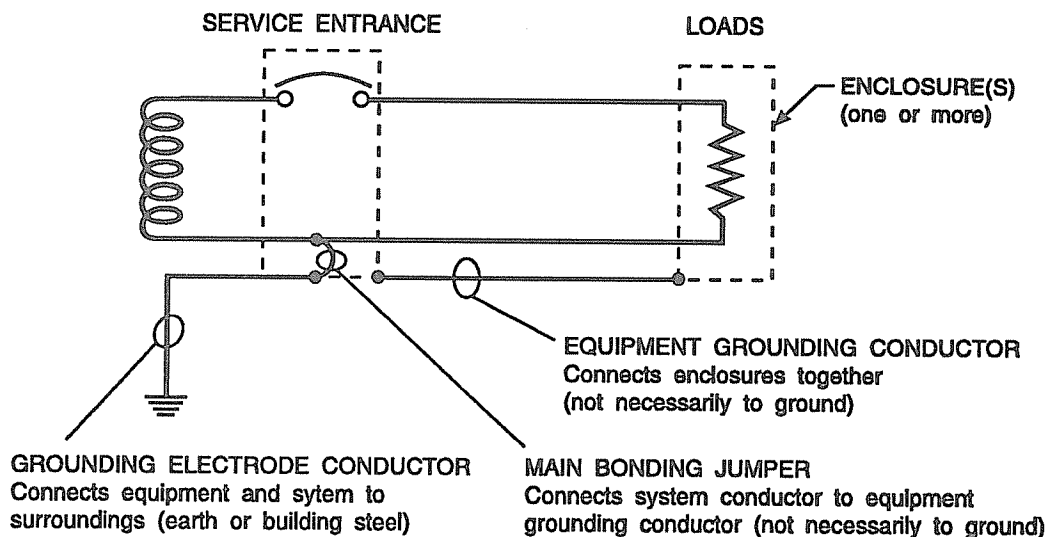



Notice that there must be a wire between the grounded conductor and the enclosure to allow the fault current to return to its source. This wire is called the *main bonding jumper*. If there is no wire, then the electrical system is isolated and requires extra safety features.

The basic idea of an overcurrent protective device is to make a weak link in the circuit. In the case of a fuse, the fuse is destroyed before another part of the system is destroyed. In the case of a circuit breaker, a set of contacts opens the circuit. Unlike a fuse, a circuit breaker can be re-used by re-closing the contacts. Fuses and circuit breakers are designed to protect equipment and facilities, and in so doing, they also provide considerable protection against shock in most situations. However, the only electrical protective device whose sole purpose is to protect people is the ground-fault circuit-interrupter. These various protective devices are further discussed below.

## Fuses

A fuse is an electrical device that opens a circuit when the current flowing through it exceeds the rating of the fuse. The "heart" of a fuse is a special metal strip (or wire) designed to melt and *blow out* when its rated amperage is exceeded.

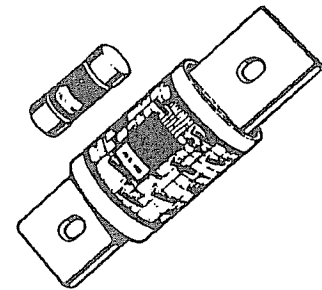

Overcurrent devices (fuses, circuit breakers) are always placed in the "hot" side of a circuit (usually a black wire) and in series with the load, so that all the current in the circuit must flow through them.

If the current flowing in the circuit exceeds the rating of the fuse, the metal strip will melt and open the circuit so that no current can flow. A fuse cannot be re-used and must be replaced after eliminating the cause of the overcurrent.



Fuses are designed to protect equipment and conductors from excessive current. It is important to always replace fuses with the proper type and current rating. Too low a rating will result in unnecessary blowouts, while too high a rating may allow dangerously high currents to pass. The symbol for a fuse is shown in the accompanying figure.



### Circuit Breaker

Circuit breakers provide protection for equipment and conductors from excessive current without the inconvenience of changing fuses. Circuit breakers *trip* (open the circuit) when the current flow is excessive.

There are two primary types of circuit breakers based on the current sensing mechanism. In the *magnetic* circuit breaker, the current is sensed by a coil that forms an electromagnet. When the current is excessive, the electromagnet actuates a small armature that pulls the trip mechanism - thus opening the circuit breaker. In the *thermal-type* circuit breaker, the current heats a bi-metallic strip, which when heated sufficiently bends enough to allow the trip mechanism to operate. The symbol for a circuit breaker is shown in the accompanying figure.



### Ground-Fault Circuit-Interrupter

A ground-fault circuit-interrupter is not an overcurrent device. A GFCI is used to open a circuit if the current flowing to the load does not return by the prescribed route. In a simple 120 volt circuit we usually think of the current flowing through the black (ungrounded) wire to the load and returning to the source through the white (grounded) wire. If it does not return through the grounded wire, then it must have gone somewhere else, usually to ground. The



GFCI is designed to limit electric shock to a current- and time-duration value below that which can produce serious injury. The operation of the GFCI will be discussed later in this module.



## GROUNDING

Grounding must be taken into account wherever electrical current flows. It can never be stressed too strongly that proper grounding and bonding must be correctly applied if the system, the equipment, and the people that come in contact with them are to be protected.

*Effective grounding* means that the path to ground: (1) is permanent and continuous, and (2) has ample current-carrying capacity to conduct safely any currents liable to be imposed on it, and (3) has impedance sufficiently low to limit the potential above ground and to facilitate the operation of the overcurrent devices in the circuit.

*Effective bonding* means that the electrical continuity of the grounding circuit is assured by proper connections between service raceways, service cable armor, all service equipment enclosures containing service entrance conductors, and any conduit or armor that forms part of the grounding conductor to the service raceway.

The requirement for effective grounding is one of the most frequently cited violations of OSHA's electrical standards. *Effective grounding has no function unless and until there is electrical leakage from a current-carrying conductor to its enclosure.* When such a *ground fault* occurs, the equipment grounding conductor goes into action to provide the following:

- It *prevents voltages* between the electrical enclosure and other enclosures or surroundings.
- It *provides a path* for large amounts of fault or overload current to flow back to the service entrance, thus blowing the fuse or tripping the circuit breaker.



### How does grounding do its job?

Proper grounding requires connecting all of the enclosures (equipment housings, boxes, conduit, etc.) together, and back to the service entrance enclosure. This is accomplished by means of the green wire in the cord (portable equipment), and the conduit system or a bare wire in the fixed wiring of the building.

When a ground fault occurs, as in a defective tool, the grounding conductor must carry enough current to immediately trip the circuit breaker or blow the fuse. This means that the ground fault path must have low impedance. The only low impedance path is the green wire (in portable cord) and the metallic conduit system (or an additional bare wire if conduit is not used).

Note that the normal useful current flows in the "current-carrying" loop from the transformer over the black wire, through the tool motor and back over the white wire to the transformer. The grounding conductor carries no current. See the figure below.

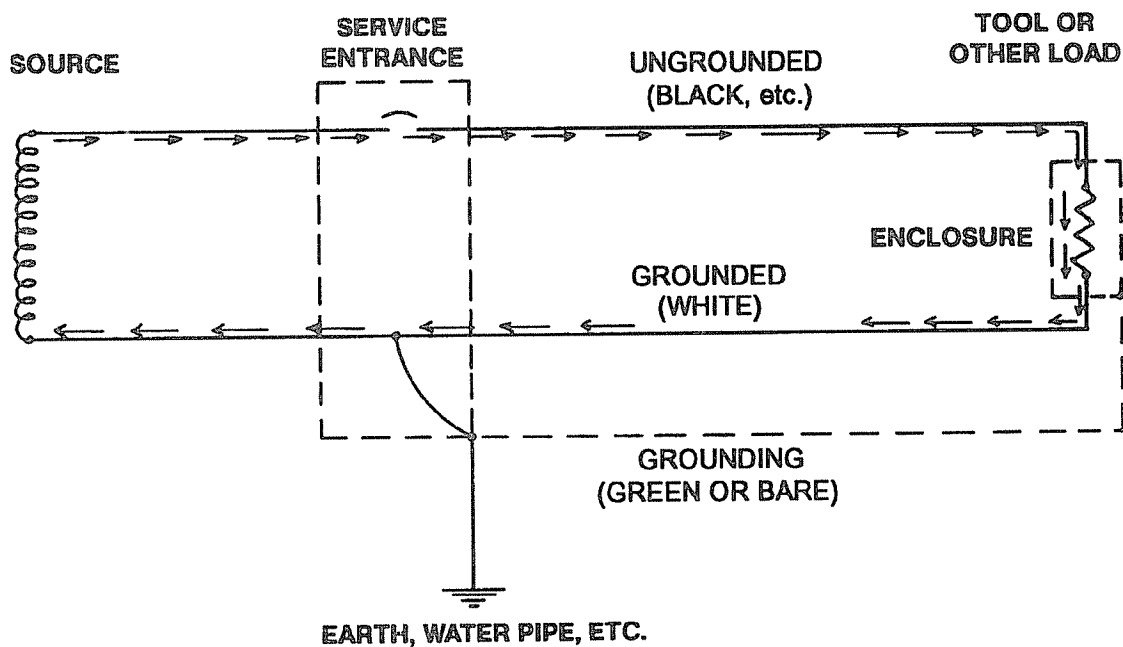



However, when the insulation on the black (ungrounded) conductor fails and the copper conductor touches the case of the tool, the ground-fault current flows through the green (grounding) conductor and the conduit system back to the service entrance. This is shown in the figure below.

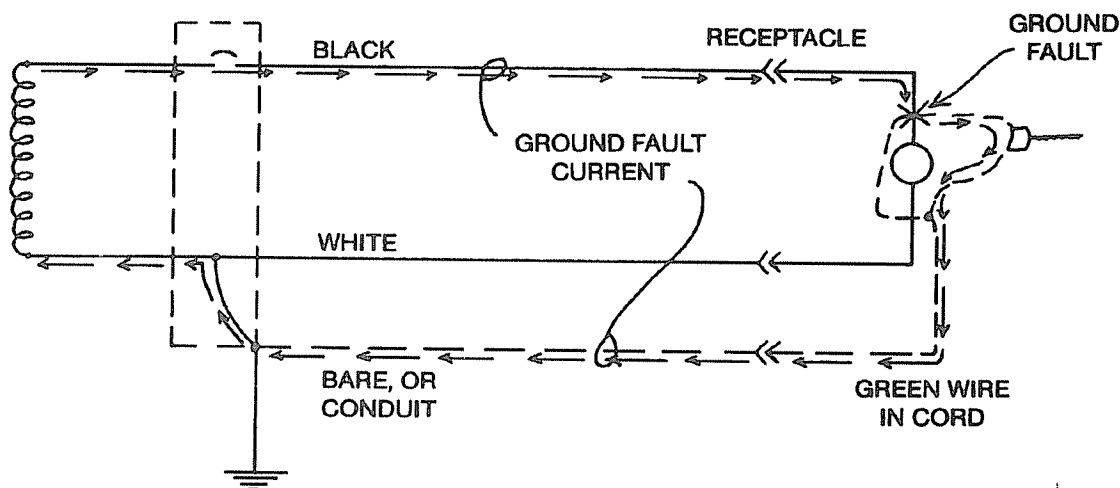

**THE GROUND FAULT LOOP**  
(THE METALLIC CONDUIT, OR A BARE WIRE IN PLACE OF CONDUIT, PROVIDES THE LOW-IMPEDANCE GROUND-FAULT PATH.)

*If the equipment-grounding conductors are properly installed, this current will be perhaps 10 times or more greater than normal current, so the circuit breaker will trip out immediately.*





### But what happens if the grounding does not do the job?

If the ground-fault path is not properly installed, it may have such high impedance that it does not allow a sufficiently large amount of current to flow. Or, if the grounding conductor continuity has been lost (as when the "U"-shaped grounding prong has been broken off the plug), no fault current will flow. In these cases, the circuit breaker will not trip out, the case of the tool will be energized, and *persons touching the tool may be shocked*. See figure below.

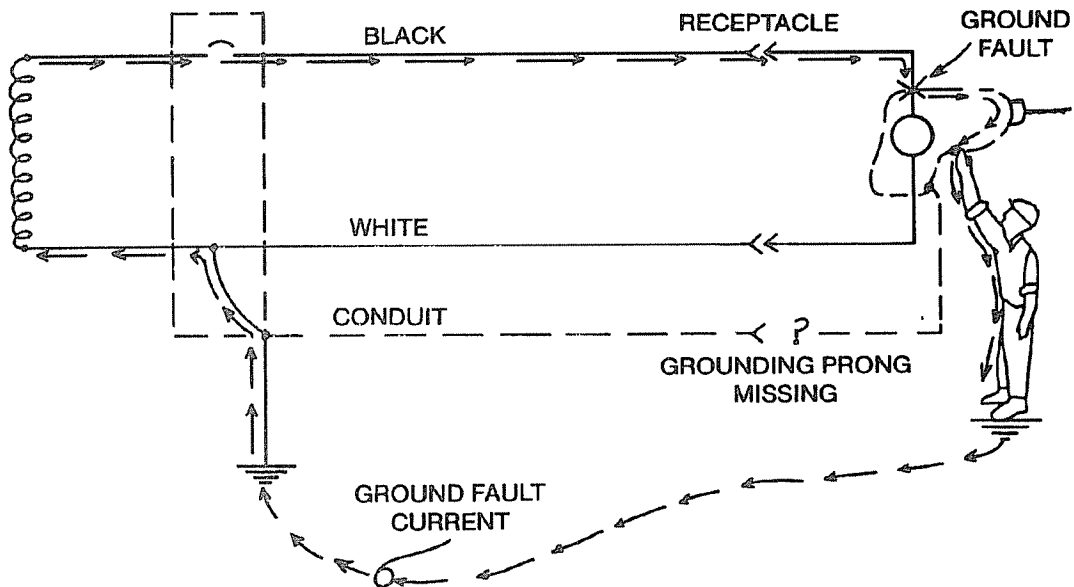

**EQUIPMENT-GROUNDING CONDUCTOR NOT COMPLETE  
(THEREFORE THE CIRCUIT BREAKER DOES NOT TRIP OUT WHEN GROUND-  
FAULT OCCURS.)**



The hazard created is that persons touching the tool may provide a path through their body and eventually back to the source of voltage. This path may be through other surfaces in the vicinity, through building steel, or through earth. The dangerous ground-fault current flowing through this high-impedance path will not rise to a high enough value to immediately trip the circuit breaker. Only the metallic equipment-grounding conductor, which is carried along with the supply conductors, will have impedance sufficiently low so that the required large amount of fault current will flow.

So the only way to ensure that the equipment grounding conductor does its job is to be certain that the grounding wire, the grounding prong, the grounding receptacle, and the conduit system are intact and have electrical continuity from each electrical tool back to the service entrance. This is illustrated in the figure below.

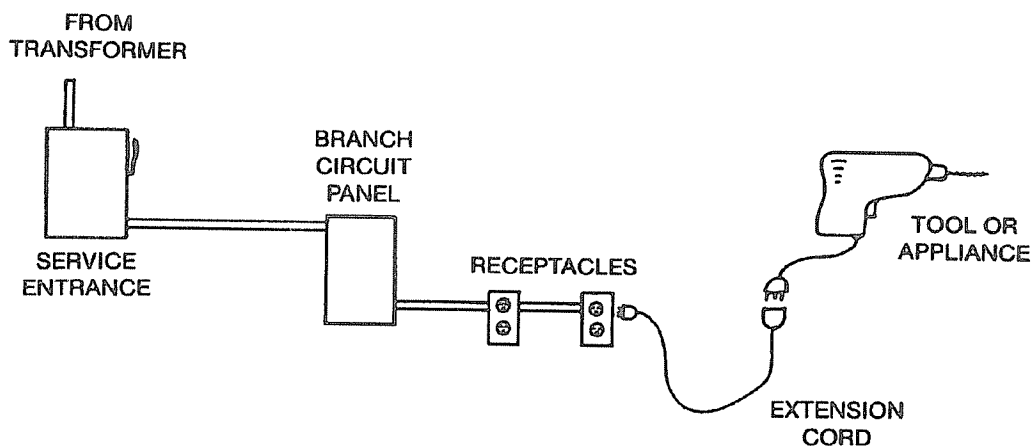

PICTORIAL DIAGRAM OF TYPICAL INSTALLATION

THE FIXED WIRING FROM THE SERVICE ENTRANCE TO THE RECEPTACLES PROVIDES EQUIPMENT GROUNDING THROUGH CONDUIT OR A BARE WIRE. THE FLEXIBLE CORDS PROVIDE GROUNDING THROUGH A GREEN WIRE AND THE U-SHAPED PRONGS, THUS COMPLETING THE GROUND-FAULT PATH.



As we have discussed, effective grounding along with overcurrent devices (fuses and circuit breakers) are used to protect equipment and facilities, and in so doing, they may also provide considerable protection against shock in most situations. However, the only protective device whose sole purpose is to protect people is the ground-fault circuit-interrupter. The GFCI is discussed in the next section of this module.



## GROUND-FAULT CIRCUIT-INTERRUPTERS

### Introduction

In most cases, *insulation* and *grounding* are used to prevent injury from electrical wiring systems or equipment. However, there are instances when these recognized methods do not provide the degree of protection required. To help appreciate this, let's consider a few examples of where ground fault circuit interrupters would provide additional protection.

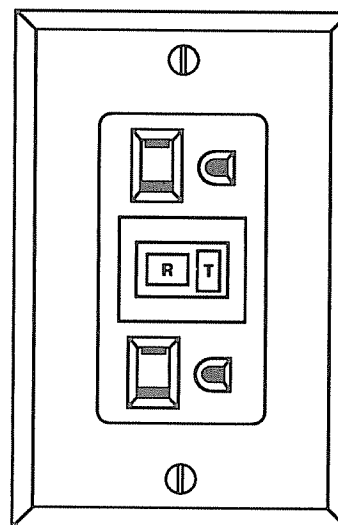

- Many portable hand tools, such as electric drills, are now manufactured with non-metallic cases. If approved, we refer to such tools as *double insulated*. Although this design method assists in reducing the risk from grounding deficiencies, a shock hazard can still exist. In many cases, persons must use such electrical equipment where there is considerable moisture or wetness. Although the person is *insulated* from the electrical wiring and components, there is still the possibility that water can enter the tool housing. Ordinary water is a conductor of electricity. Therefore, if the water contacts energized parts, a path will be provided from inside the housing to the outside, bypassing the *double insulation*. When a person holding a hand tool under these conditions touches another conductive surface in their work environment, an electric shock will result.
- Double-insulated equipment or equipment with non-metallic housings, that does not require grounding under the National Electrical Code, is frequently used around sinks or in situations where the equipment could be dropped into water. Frequently, the initial human response is to grab for the equipment. If a person's hand is placed in the water and another portion



of their body is in contact with a conductive surface, a serious or deadly electric shock can occur.

- In construction work and regular factory maintenance work, it is frequently necessary to use extension cord sets with portable equipment. These cords are regularly exposed to physical damage. Although safe work procedures require adequate protection, it is not possible to prevent all damage. Frequently, the damage is only to the insulation, exposing energized conductors. It is not unusual for a person to handle the cord often with the possibility of contacting the exposed wires while holding a metal case tool or while in contact with other conductive surfaces.

The amount of current which flows under such conditions will be enough to cause serious human response. This can result in falls or other physical injury and in many cases death.

Since neither *insulation* (double insulation) nor *grounding* can provide protection under these conditions, it is necessary to use other protective measures. One acceptable method is a ground fault circuit interrupter, commonly referred to as a GFCI.

### How Ground-Fault Circuit-Interrupters Work

A ground-fault circuit-interrupter is not an overcurrent device like a fuse or circuit breaker. GFCI's are designed to sense an imbalance in current flow over the normal path.

The GFCI contains a special sensor that monitors the strength of the magnetic field around each wire in the circuit when current is flowing. The magnetic field around a wire is directly proportional to the amount of current flow, thus the circuitry can accurately translate the magnetic information into current flow.



If the current flowing in the *black (ungrounded) wire* is within 5 ( $\pm 1$ ) milliamperes of the current flowing in the *white (grounded) wire* at any given instant, the circuitry considers the situation normal. All the current is flowing in the normal path. If, however, the current flow in the two wires differs by more than 5 mA, the GFCI will quickly open the circuit. This is illustrated in the figure below.

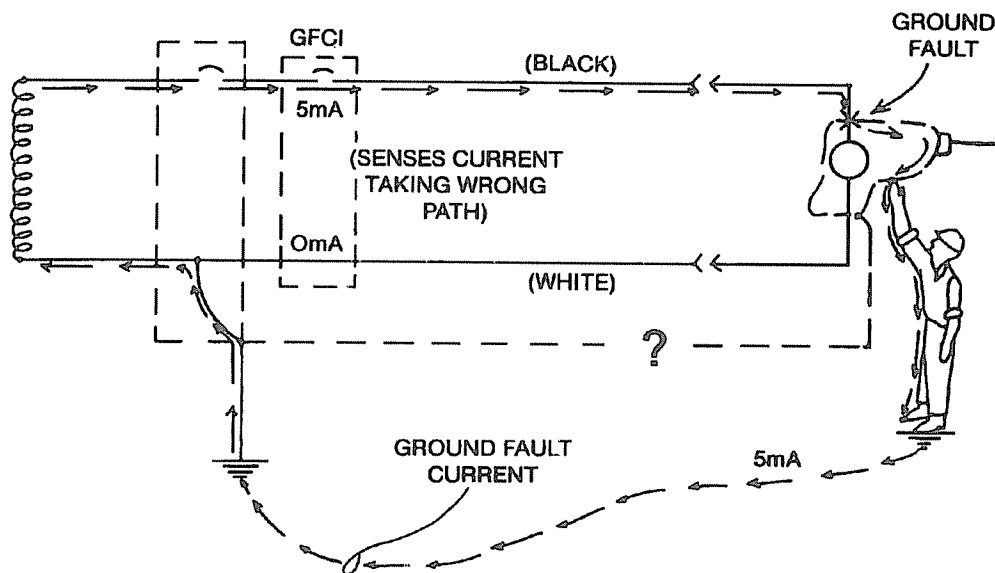

#### HOW THE GFCI PROTECTS PEOPLE

(BY OPENING THE CIRCUIT WHEN CURRENT FLOWS THROUGH A GROUND-FAULT PATH)

Note that the GFCI will open the circuit if 5 mA or more of current returns to the service entrance by any path other than the intended white (grounded) conductor. If the equipment grounding conductor is properly installed and maintained, this will happen *as soon as the faulty tool is plugged in*. If by chance this grounding conductor is not intact and of low-impedance, the GFCI may not trip out *until a person provides a path*. In this case, the person will receive a shock, but the GFCI should trip out so quickly that the shock will not be harmful.



## Types of Ground-Fault Circuit-Interrupters

There are several types of GFCI's available, with some variations to each type. Although all types will provide ground-fault protection, the specific application may dictate one type over another.

- **Circuit-Breaker Type**

The circuit-breaker type includes the functions of a standard circuit breaker with the additional functions of a GFCI. It is installed in a panelboard and can protect an entire branch circuit with multiple outlets. It is a direct replacement for a standard circuit breaker of the same rating.

- **Receptacle Type**

The receptacle style GFCI incorporates within one device one or more receptacle outlets, protected by the GFCI. Such devices are becoming very popular because of their low cost. Most are of the duplex receptacle configuration and can provide GFCI protection for additional non-GFCI type receptacles connected "down stream" from the GFCI unit.

- **Permanently Mounted Type**

The permanently mounted types are mounted in an enclosure and designed to be permanently wired to the supply. Frequently they are used around large commercial swimming pools or similar wet locations.

- **Portable Type**

Several styles of portable GFCI's are available. The portable types are designed to be easily transported from one location to another. They usually contain one or more integral receptacle outlets protected by the GFCI module. Some models are designed to plug into existing non-GFCI protected outlets, or in some cases, are connected with a cord and plug arrangement. The portable type also incorporate a no-voltage release device



which will disconnect power to the outlets if any supply conductor is open.

Units approved for use outdoors will be in enclosures suitable for the environment. If exposed to rain, they must be listed as rainproof.

- **Cord Connected Type**

The power supply cord type GFCI consists of an attachment plug which incorporates the GFCI module. It provides protection for the cord and any equipment attached to the cord. The attachment plug has a non-standard appearance and is equipped with test and reset buttons. Like the portable type, it incorporates a no-voltage release device which will disconnect power to the load if any supply conductor is open.

### Classes of Ground-Fault Circuit-Interrupters

Ground-Fault Circuit-Interrupters are divided into two classes: Class A and Class B. The Class A device is designed to trip when current flow, in other than the normal path, is 6 milliamperes or greater. The specification is 5 milliamperes  $\pm$  1 milliampere. The Class B device will trip when current flow, in other than the normal path, is 20 milliamperes or greater. Class B devices are approved for use on underwater swimming pool lighting installed prior to the adoption of the 1965 National Electrical Code.

### Testing Ground-Fault Circuit-Interrupters

Due to the complexity of a GFCI, it is necessary to test the device on a regular basis. For permanently wired devices, a monthly test is recommended. Portable type GFCI's should be tested each time before use. GFCI's have a built-in test circuit which imposes an artificial ground fault on the load circuit to assure that the ground-fault protection is still functioning. Test and reset buttons are provided for testing.





## REVERSED POLARITY

One potentially dangerous aspect of alternating current electricity is the fact that many pieces of equipment will operate properly even though the supply wires are not connected in the order designated by design or the manufacturer. Improper connection of these conductors is most prevalent on the smaller branch circuit typically associated with standard 120 volt receptacle outlets, lighting fixtures and cord- and plug-connected equipment.

Section 1910.304(a)(2) of the OSHA standards and Section 200-11 in the National Electrical Code cover the requirements for the connection of the *grounded* conductor. It is from these sections that the so-called "reversed polarity" expression comes. Although these sections are addressing the connection of the grounded conductor, it is extremely important to realize that improper termination of *any* conductor can introduce a serious hazard. The figure below shows correct wiring of a standard medium base screw-shell lamp.

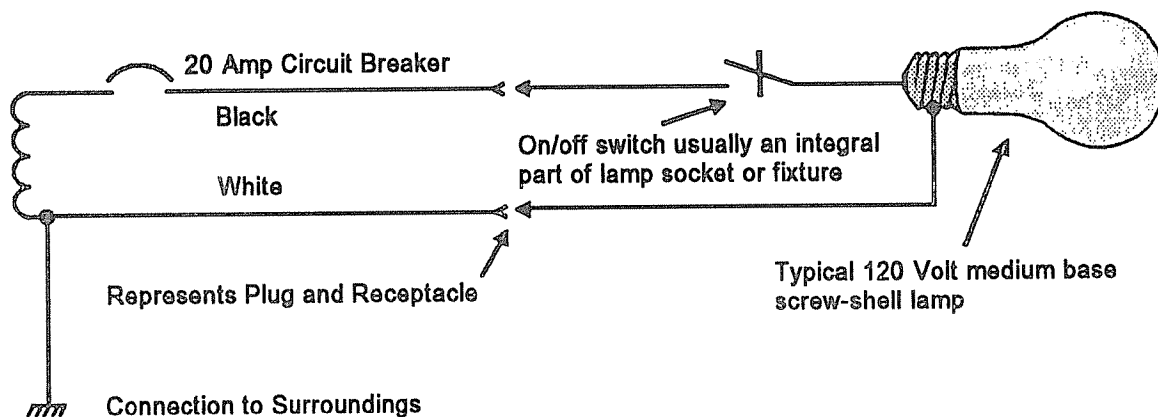

TYPICAL 120 VOLT BRANCH CIRCUIT WITH CORRECT WIRING  
MEDIUM BASE SCREW-SHELL LAMP



It is not unusual for persons to place their fingers close to or on the screw-shell when removing a lamp. When connected as shown in the figure below, the screw-shell of the lamp would be at 120 volts with reference to other conductive surfaces in the surroundings. Touching such a conductive surface in the area while in contact with the screw-shell would pose a serious shock hazard. Although it is recommended that power be turned off before doing such work, history shows that this is frequently not done. This is especially serious when persons are using cord- and plug-connected portable work lights with grounded metal guards or reflectors. Notice that a person may think that the power has been turned off by the integral switch on the hand-lamp; however, due to the "reversed polarity" the switch is not located in the energized wire and does not remove power from the screw-shell of the lampholder. Typically a person will hold the fixture by the grounded metal guard. If the person's fingers come in contact with the screw-shell of the lamp under such conditions, 120 volts will be applied to the body from hand to hand.

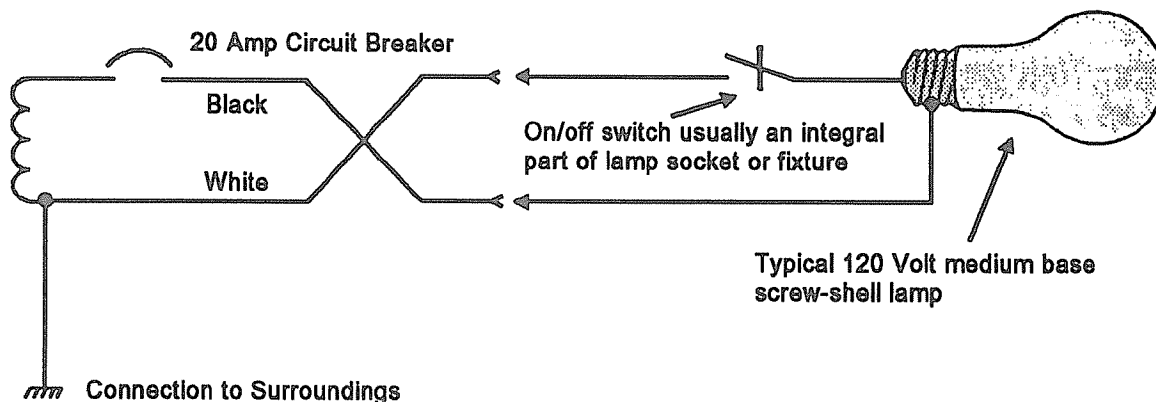

TYPICAL 120 VOLT BRANCH CIRCUIT WITH INCORRECT WIRING  
MEDIUM BASE SCREW-SHELL LAMP



The figure below shows the correct wiring for the common 120 volt outlet with a portable hand tool attached.

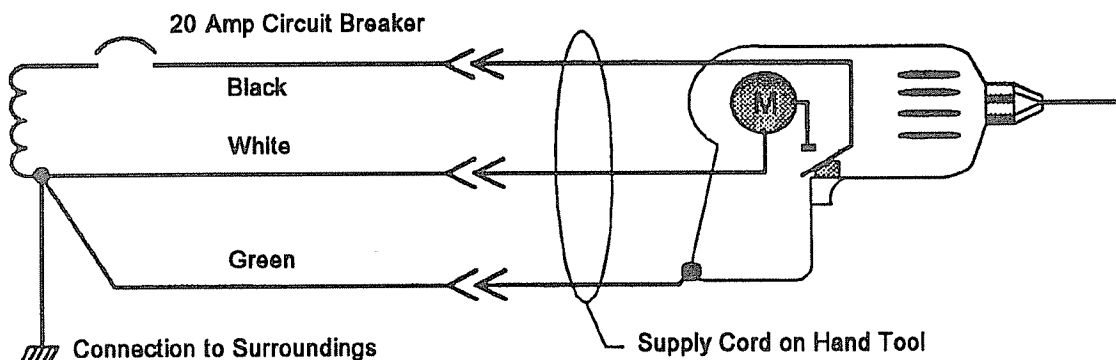

TYPICAL 120 VOLT BRANCH CIRCUIT WITH CORRECT WIRING

Suppose now that the black (ungrounded) and white (grounded) conductors are reversed as shown in the figure below. This is the traditional *reversed polarity*. Although a shock hazard may not exist, there are other mechanical hazards that can occur.

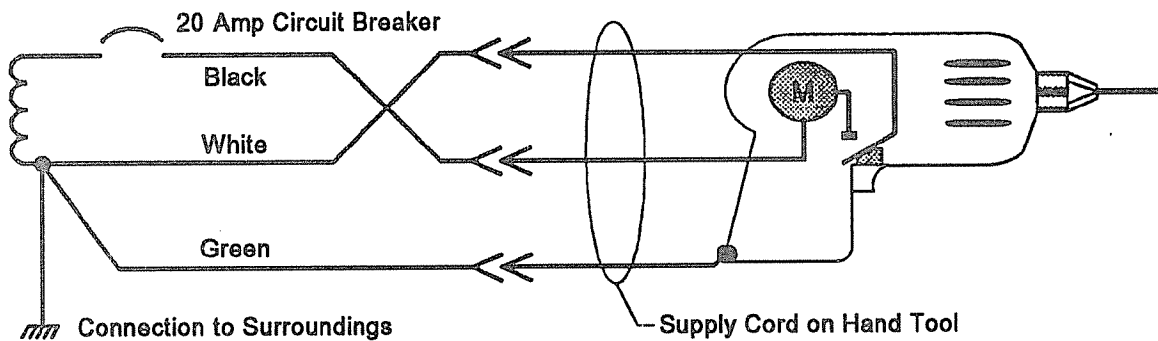

120 VOLT BRANCH CIRCUIT WITH BLACK AND WHITE WIRES REVERSED



For example, if an internal fault should occur in the wiring as shown in the figure below, the equipment would not stop when the switch is released or would start as soon as a person plugs the supply cord into the improperly wired outlet. This could result in serious injury.

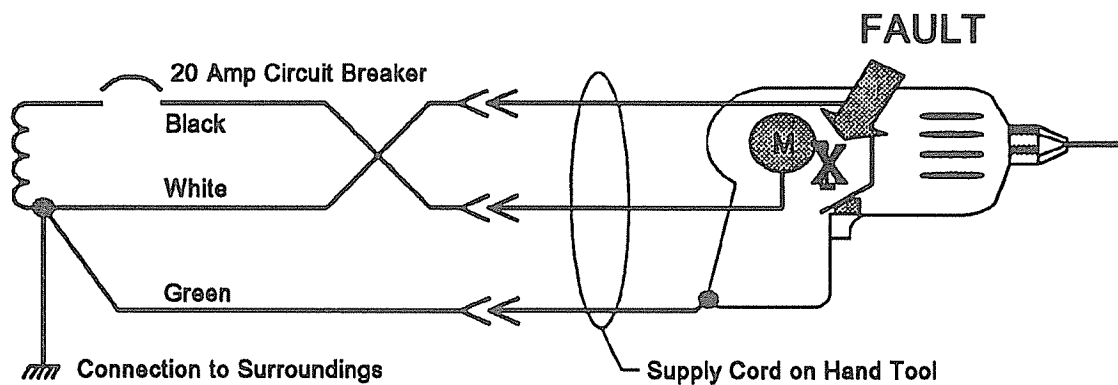

**120 VOLT BRANCH CIRCUIT WITH BLACK AND WHITE WIRES REVERSED  
INTERNAL FAULT IN EQUIPMENT WIRING**



The figure below shows the white (grounded) and green (grounding) conductors reversed. Although it is not fitting, considering OSHA or code terminology, to call this *reversed polarity*, a hazard can still exist. In this case, due to the wiring error, the white wire is being used to provide equipment grounding. Under certain conditions, this could be dangerous.

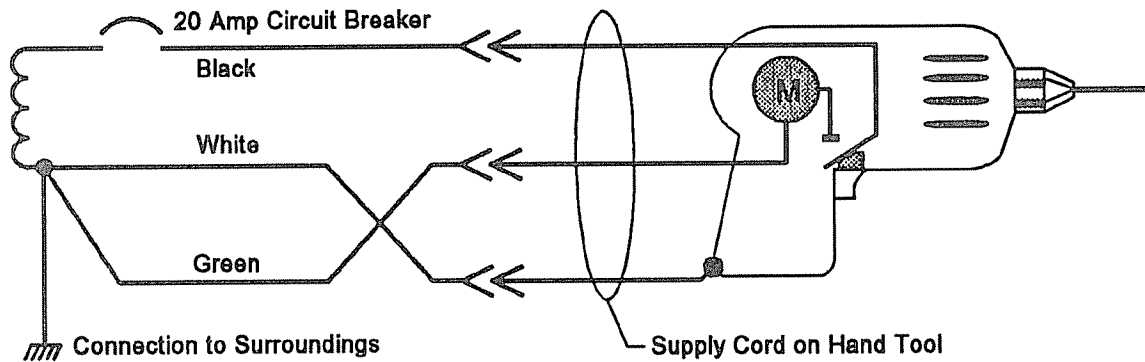

WHITE AND GREEN WIRES REVERSED



The figure below shows an *extremely* dangerous situation. In this example, the black (ungrounded) and green (grounding) conductors have been reversed. The metal case of the equipment is at 120 volts with reference to the surroundings. As soon as a person picks up the equipment and touches a conductive surface in their surroundings, they will receive a serious, or even deadly, shock.

Although the equipment will not work with this wiring error, it would not be unusual for a person to pick up the equipment before realizing this. The person may even attempt to trouble-shoot the problem before unplugging the power cord.

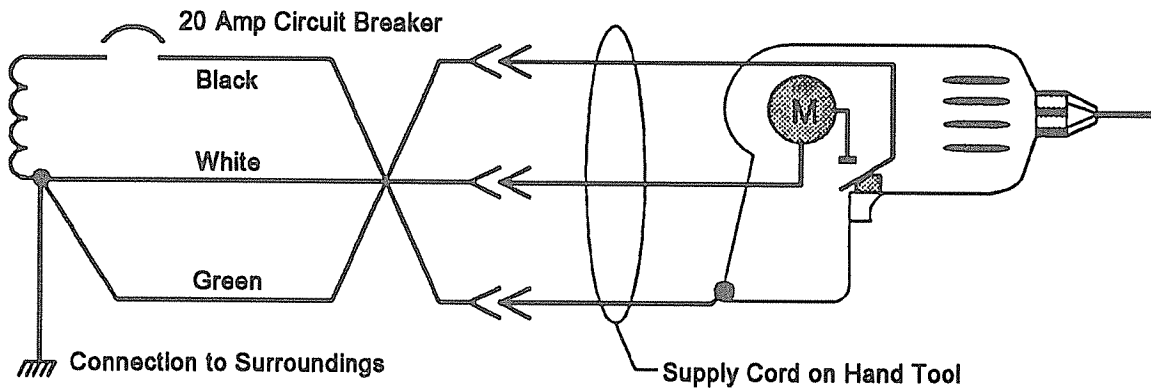

BLACK AND GREEN WIRES REVERSED



Correct polarity is achieved when the grounded conductor is connected to the corresponding grounded terminal and the ungrounded conductor is connected to the corresponding ungrounded terminal. The reverse of the designated polarity is prohibited. The figure below illustrates a duplex receptacle correctly wired. Terminals are designated and identified to avoid confusion. An easy way to remember the correct polarity is "white to light" - the white (grounded) wire should be connected to the light or nickel-colored terminal; "black to brass" - the black or multi-colored (ungrounded) wire should be connected to the brass terminal; and "green to green" - the green or bare (grounding) wire should be connected to the green hexagonal head terminal screw.

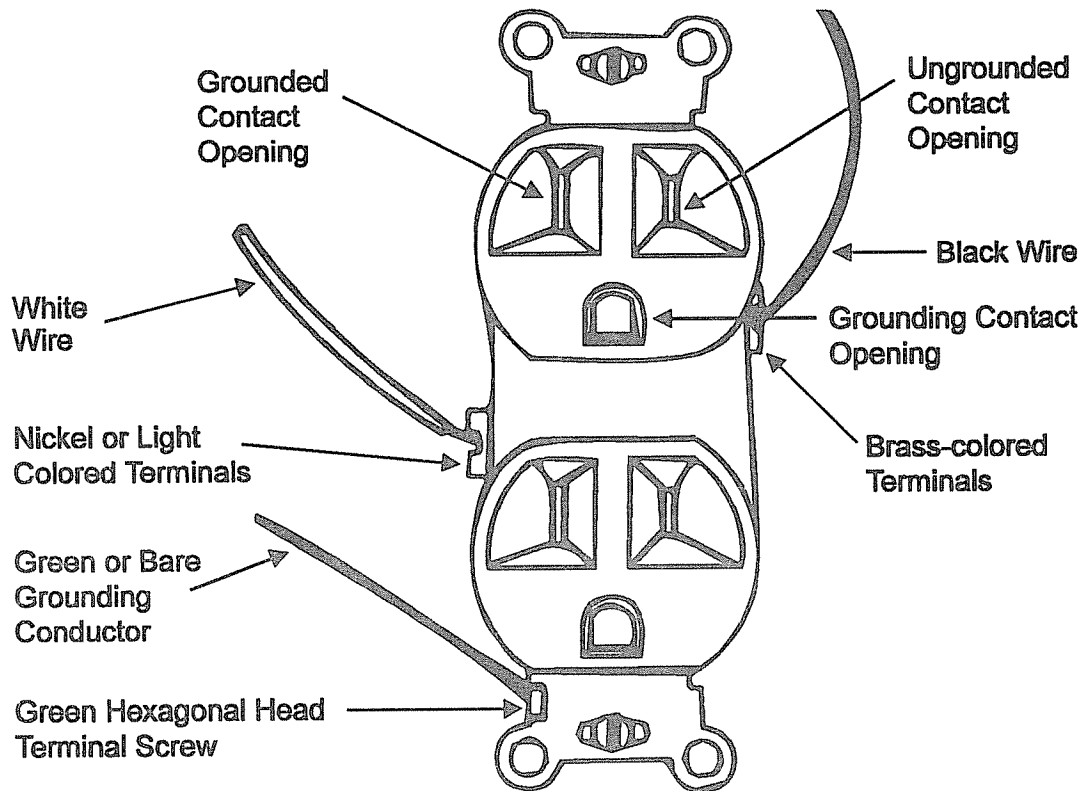

DUPLEX RECEPTACLE CORRECTLY WIRED TO DESIGNATED TERMINALS



## GLOSSARY

**Alternating Current (ac).** The type of electric current which reverses at regularly recurring intervals of time and which has alternately positive and negative values.

**Ampere.** The unit of measurement for the rate of flow of electricity.

**Atom.** The smallest particle into which an element can be divided chemically.

**Capacitance.** The ability to accumulate and give up charge. When the voltage across an electric circuit changes, the circuit opposes this change due to capacitance. Capacitance affects dc circuits *only* when they are turned on and off. In ac circuits, however, the voltage is continuously changing, so that the effect of capacitance is *continuous*.

**Closed Circuit.** A complete path allowing current to flow.

**Conductor.** A material that gives up free electrons and offers only slight opposition to current flow. Metals are good conductors. Copper and aluminum are very good conductors.

**Current.** The rate of flow of electricity in a circuit. Measured in amperes. The symbol for current is the letter I.

**Direct Current (dc).** The type of electric current in which the electrons move continuously in one direction through the conductor.





**Direction of Current Flow.** Electrons flow from a negatively charged point to a positively charged point. When one point in an electrical circuit is marked (-) and the other is marked (+), by convention, the current in the circuit flows from the (+) to the (-).

**Electromagnetism.** The magnetic effect created when an electric current flows in a conductor. This magnetic effect surrounds the conductor only while current is flowing.

**Electromotive Force (EMF).** The electrical force caused by a difference in potential between two points. EMF is measured in volts.

**Electron.** A negatively charged particle with a very small mass. It orbits around the nucleus of an atom.

**Free Electrons.** Electrons in the outer orbits of an atom that can easily be forced out of their orbits.

**High Voltage.** A term that normally implies a voltage higher than 600 volts.

**Impedance.** The total opposition offered to the flow of an alternating current. It may consist of any combination of resistance, inductive reactance, and capacitive reactance. Impedance is measured in ohms and its symbol is the letter Z. The relationship among impedance, reactance and resistance is shown in equation form below.

$$Z = \sqrt{R^2 + X^2}$$



**Inductance.** The property of an electric circuit by virtue of which a varying current induces an electromotive force in that circuit or a neighboring circuit. When the current in an electric circuit changes, the circuit may *oppose* the change due to inductance.

**Induction.** The act or process of producing voltage by the relative motion of a conductor across a magnetic field.

**Insulator.** A material that does not give up free electrons easily and offers opposition to current flow. Some of the best insulators are polystyrene, mica, glass, and wood.

**Neutron.** The particle in the nucleus which has no electrical charge.

**Open Circuit.** A break in the circuit which stops current flow. In a series circuit, it means the complete circuit is dead.

**Ohm.** The basic unit of resistance measure. One ohm is equal to the resistance that allows 1 ampere of current to flow when an EMF of 1 volt is applied. The symbol for ohm is the greek letter *omega* ( $\Omega$ ).

**Ohm's Law.** The voltage (E) is equal to the current (I) times the resistance (R). The formula is written:

$$E = IR$$



**Parallel Circuit.** A circuit having its electrical components or equipment connected so the total current is divided among them.

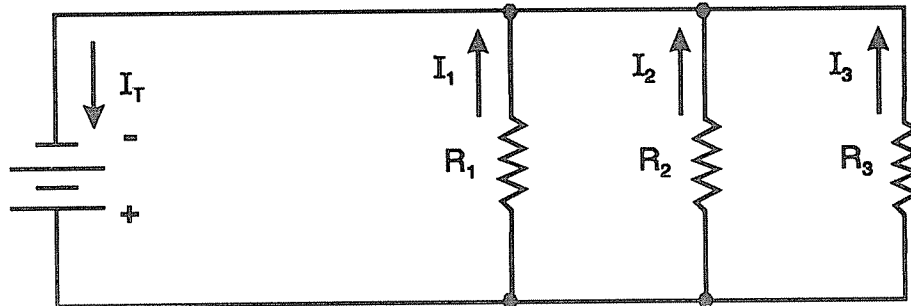

**Parallel Circuit Laws.**

*Current* - The total current is the *sum* of the individual branch currents.

*Voltage* - Voltage is the same across each branch in a parallel circuit.

*Resistance* - Total resistance is *less* than the lowest resistance. As more resistors are connected in parallel to a line, the total effective resistance of the combination is reduced, and the line current increases. This is shown in equation form below.

$$\frac{1}{R_T} = \frac{1}{R_1} + \frac{1}{R_2} + \frac{1}{R_3}$$



**Power.** The energy consumed in an electrical circuit. Power is the voltage times the current, and its symbol is the letter P. Power is measured in watts. In equation form:

$$P = EI$$

**Proton.** The positively charged particle in the nucleus.

**Reactance.** The opposition offered to the flow of an alternating current due to the changing magnetic field outside the conductor. This opposition is measured in ohms. Reactance causes the current to lead or lag the voltage by 90 electrical degrees. Its symbol is the letter X.

**Resistance.** The opposition to the flow of electrons or current flow in a circuit due to characteristics of the material. The resistivity of a pure material depends on the number of free electrons available along the current path. Resistance is measured in ohms and its symbol is the letter R.

**Series Circuit.** A circuit that has *one and only one* path for current flow.

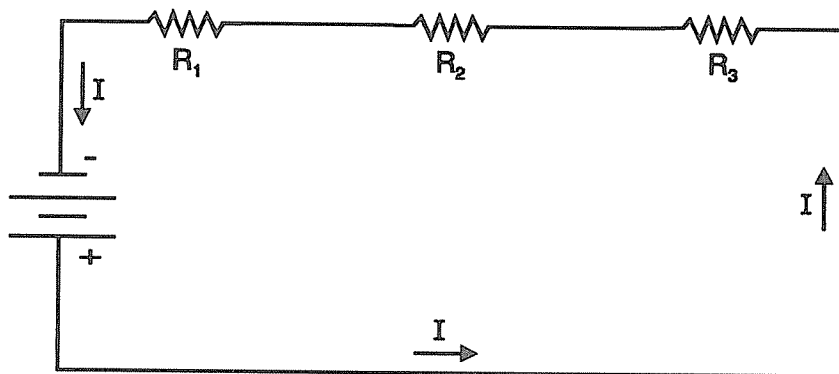



**Series Circuit Laws.**

*Current* - Current is the *same* throughout a series circuit.

*Voltage* - Source voltage equals the *sum* of the individual voltage drops.

*Resistance* - Total resistance is the *sum* of the individual resistances. To find the current in a series circuit, divide the line voltage applied to the circuit by the total resistance. The total of individual voltage drops always equals the applied line voltage.

**Short Circuit.** When the resistance of any part of a complete circuit drops from its normal value to a very low resistance.

**Volt.** The unit of measure for electromotive force.

**Voltage.** The force (potential) that causes the current to flow. Measured in volts. The symbol for voltage is the letter E.

(

(

(