

Tools – Hand and Power

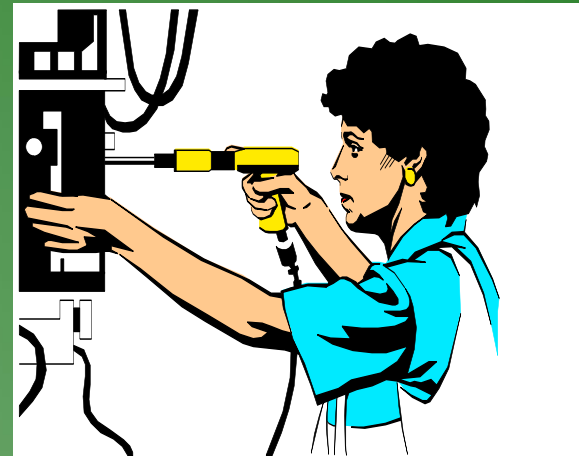

Hazards

Workers using hand and power tools may be exposed to these hazards:

- objects that fall, fly, are abrasive, or splash
- harmful dusts, fumes, mists, vapors, and gases
- frayed or damaged electrical cords, hazardous connections and improper grounding

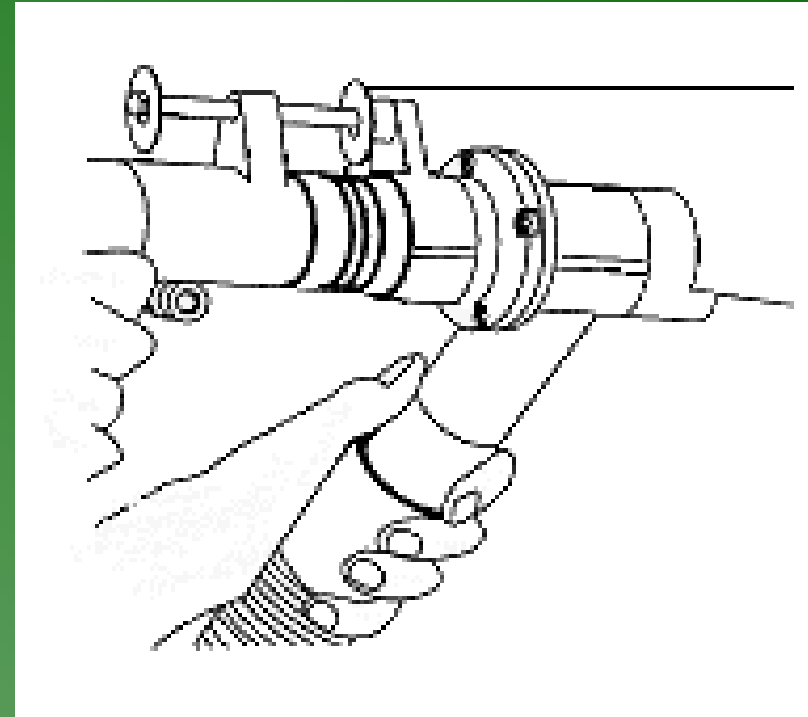

Basic Tool Safety Rules

- Maintain regularly
- Use right tool for the job
- Inspect before use
- Operate according to manufacturers' instructions
- Use the right personal protective equipment (PPE)
- Use guards



Hand Tool Hazards

Hazards are usually caused by misuse and improper maintenance

Do not use:

- wrenches when jaws are sprung
- impact tools (chisels and wedges) when heads have mushroomed
- tools with loose, cracked or splintered handles
- a screwdriver as a chisel
- tools with taped handles – they may be hiding cracks

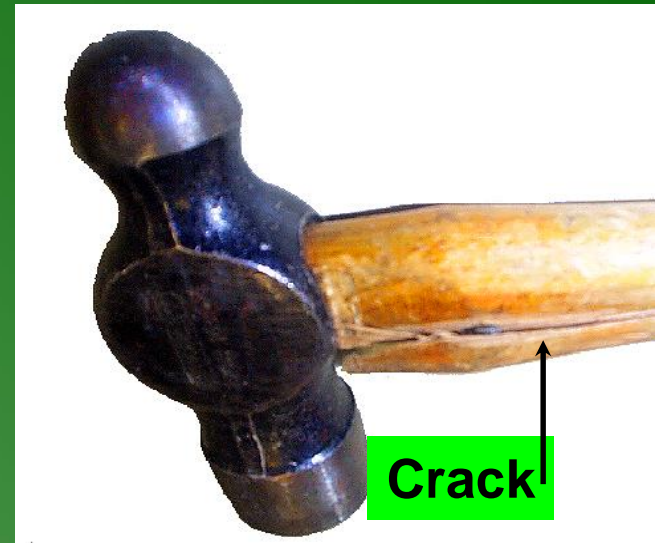

Hand Tools - Protection

Use PPE, such as safety goggles and gloves

Keep floor surface where working free from debris and tripping or slipping hazards

Keep cutting tools sharp



Power Tools

Must be fitted with guards
and safety switches

Extremely hazardous
when used improperly

Different types, determined
by their power source:

- Electric
- Pneumatic
- Liquid fuel
- Hydraulic
- Powder-actuated



Switches

Hand-held power tools must be equipped with one of the following:

Constant pressure switch
shuts off power upon release

Examples: circular saw, chain saw, grinder, hand-held power drill

On-Off Switch

Examples: routers, planers, laminate trimmers, shears, jig saws, nibblers, scroll saws



Power Tools - Precautions

- Disconnect tools when not in use, before servicing and cleaning, and when changing accessories
- Keep people not involved with the work away from the work
- Secure work with clamps or a vise, freeing both hands to operate the tool
- Don't hold the switch button while carrying a plugged-in tool
- Keep tools sharp and clean
- Consider what you wear – loose clothing and jewelry can get caught in moving parts
- Remove damaged electric tools & tag them: “Do Not Use”

Power Tools – Precautions

Electric Cords



Don't carry portable tools by the cord

Don't use electric cords to hoist or lower tools

Don't yank cord or hose to disconnect it

Keep cords and hoses away from heat, oil, and sharp edges

Electric Power Tools

To protect a worker from shock, these tools must:

- have a 3-wire cord plugged into a grounded receptacle
- be double insulated, or
- be powered by a low-voltage isolation transformer



Double
insulated
markings



Plug with a
grounding
pin

Electric Tools – Good Practices

- Operate within design limits
- Use gloves and safety shoes
- Store in a dry place
- Don't use in wet locations unless approved for that
- Keep work areas well lit
- Ensure cords don't present a tripping hazard

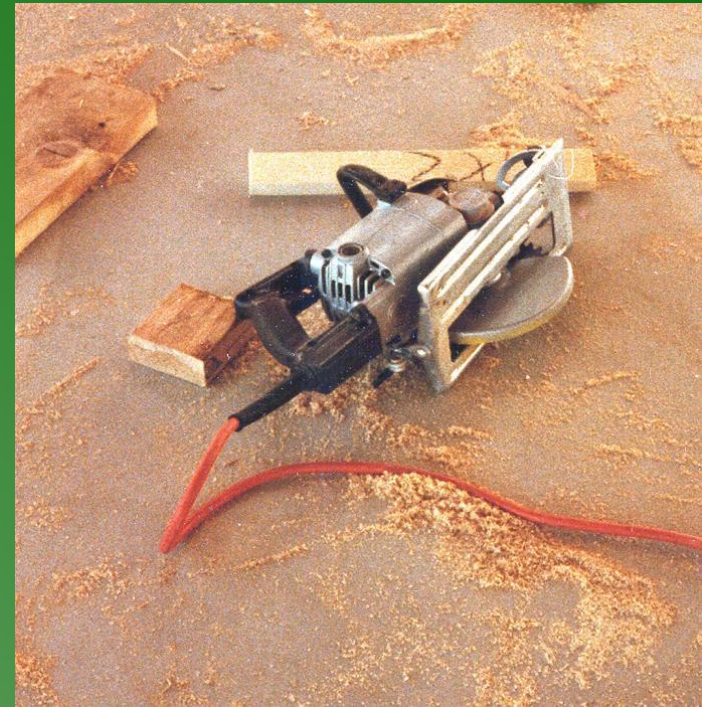

Abrasive Wheels and Tools

May throw off flying fragments

Equip with guards that:

- Cover the spindle end, nut, & flange projections
- Maintain proper alignment with the wheel
- Don't exceed the strength of the fastenings

Guard so that a minimal amount of the wheel is exposed



Inspecting Abrasive Wheels

Before mounting:

- inspect closely for damage
- perform sound- or ring-test to ensure free from cracks / defects

To test:

- tap wheel gently with a light, non-metallic instrument
- if wheel sounds cracked or dead, do not use it because it could fly apart



Abrasive Wheel Use

To prevent cracking:

- fit the wheel on the spindle freely
- tighten the spindle nut enough to hold the wheel in place without distorting the flange

Let the tool come up to speed prior to grinding or cutting

Don't stand in front of the wheel as it comes up to full speed

Use eye and/or face protection



Ensure the spindle speed doesn't exceed the maximum speed marked on the wheel

Abrasive Wheel Work Rests

Keep work rests not more than 1/8th inch from wheel surface

This prevents jamming the work between the wheel and the rest, which may cause the wheel to break

Don't adjust wheel while it's rotating

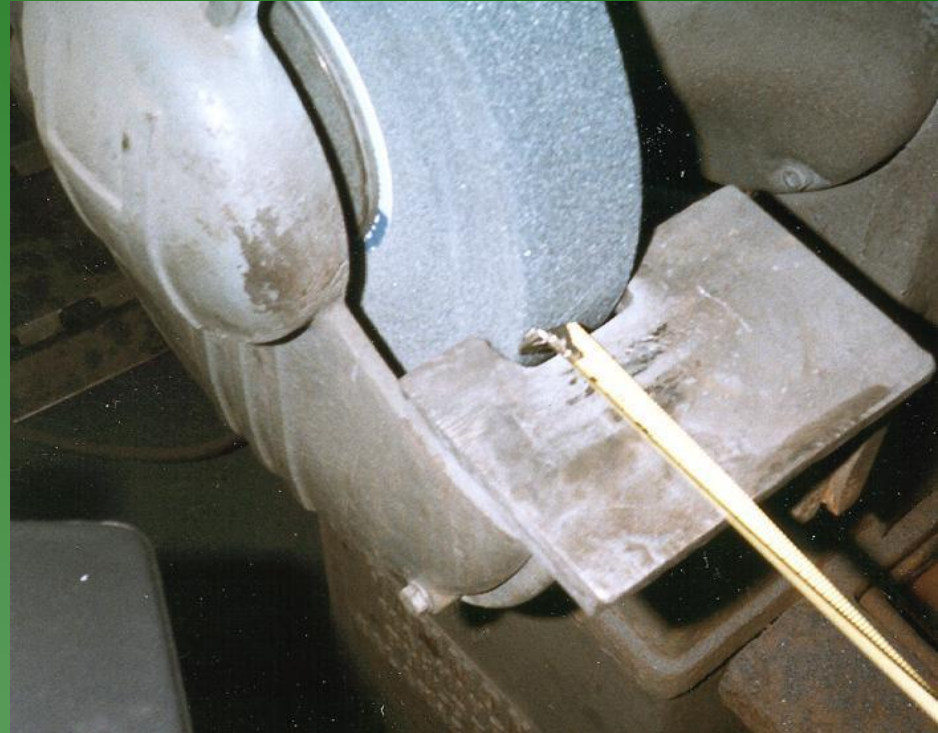

Guarding

Guard exposed moving parts of power tools

Guard belts, gears, shafts, pulleys, sprockets, spindles, flywheels, chains, or other moving parts

Never remove a guard when a tool is in use



Guarding - Point of Operation



This shows a radial arm saw equipped with proper point of operation guards

The point of operation is where the work is actually performed on the materials – it must be guarded

Guarding Protection

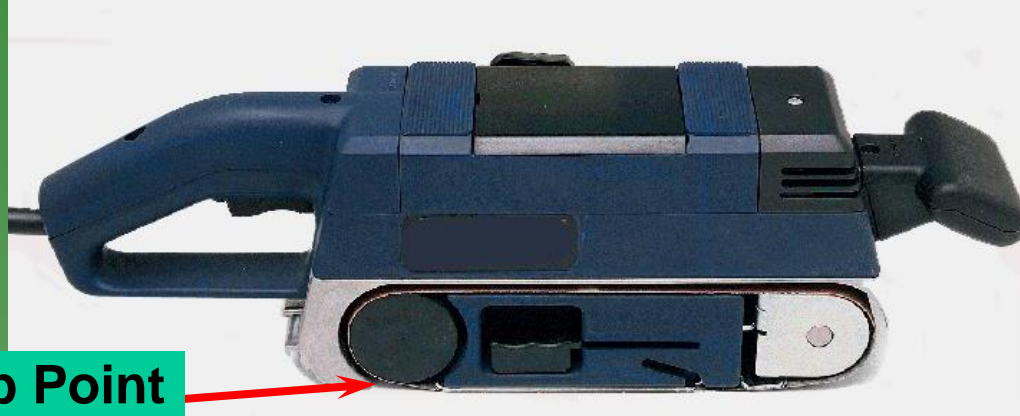

Machine guards must protect the operator and others from:

- **Point of operation**
- **In-running nip points**
- **Rotating parts**
- **Flying chips and sparks**

Radial Saw Guarding



Radial arm saw
equipped with an
upper and lower
blade guard

Guard to prevent the operator from coming
in contact the the rotating blade

Guarding Portable Circular Saws

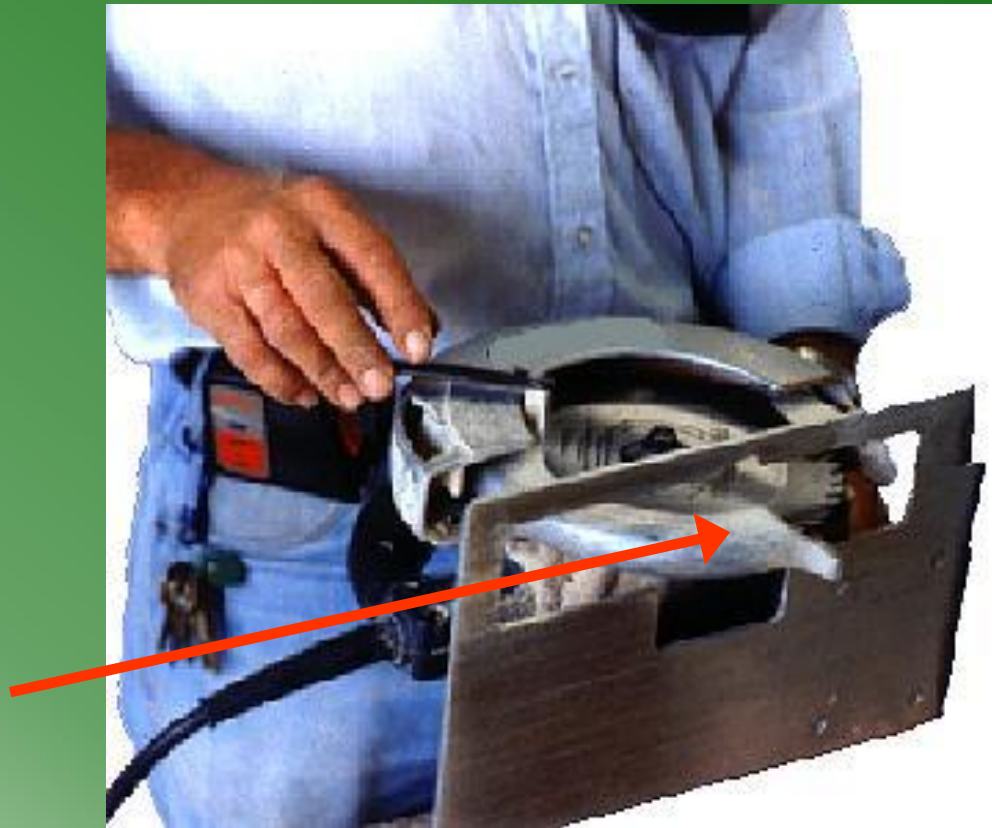

Guard these saws above and below the base plate or shoe.
The lower guard must cover the saw to the depth of the teeth.

Table Saw Guarding

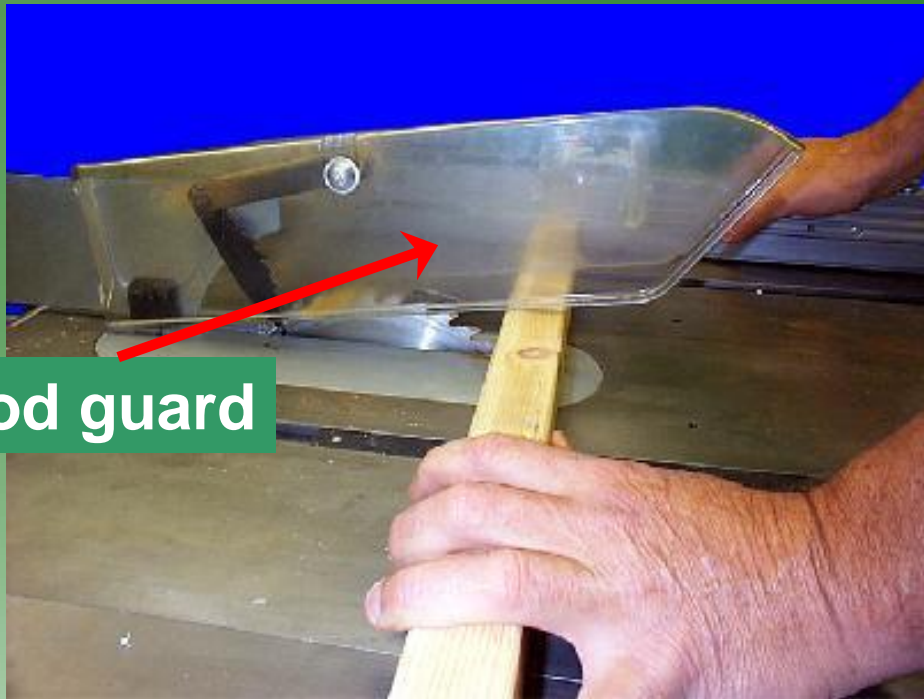

Hood guard



Use a hood for guarding

Pneumatic Tools

Powered by compressed air

Includes nailers, staplers, chippers, drills & sanders

Main hazard - getting hit by a tool attachment or by a fastener the worker is using with the tool

Take the same precautions with an air hose that you take with electric cords



**Nail Gun -
Cut-Away View**

Pneumatic Tools - Fastening

Ensure tool is fastened securely to the air hose to prevent a disconnection

Use a short wire or positive locking device attaching the air hose to the tool

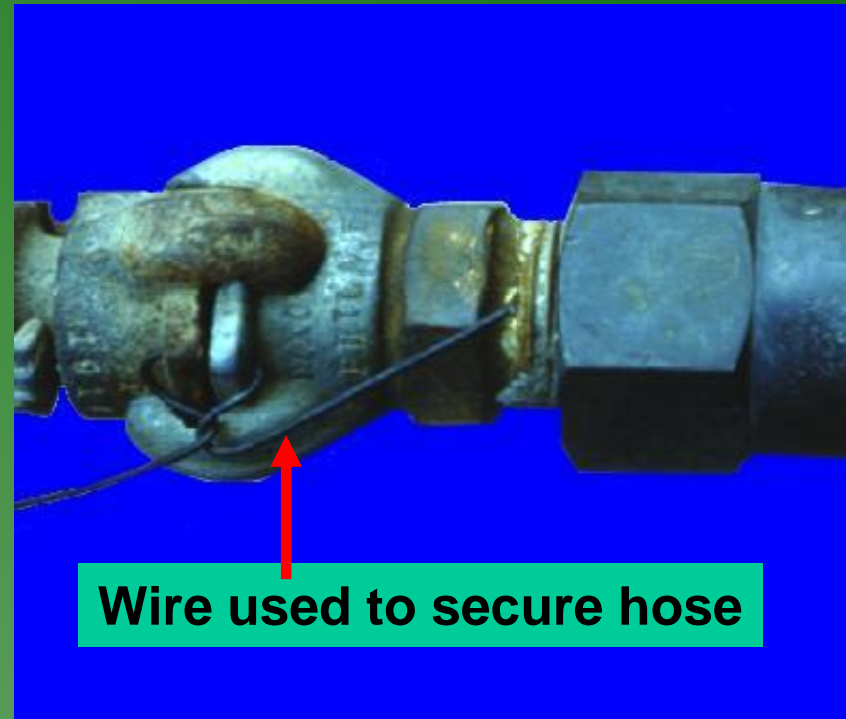

Pneumatic Tool Connections



← Unacceptable



← Acceptable

Pneumatic Tool Safety

Place a safety device on the muzzle to prevent the tool from ejecting fasteners, unless the muzzle is in contact with work surface

Install a safety clip or retainer to prevent attachments, such as chisels on a chipping hammer, from being ejected

Wear eye protection. Wear hearing protection with jackhammers.



Compressed Air Cleaning



Don't use compressed air for cleaning

Exception - where reduced to less than 30 p.s.i. with effective chip guarding and PPE

Liquid Fuel Tools

Usually gas powered

Main hazard – fuel vapors

Use only approved flammable liquid containers

Before refilling a fuel-powered tool tank, shut down the engine and allow it to cool



Powder-Actuated Tools

User must be trained and licensed to operate

Test tool each day before loading to ensure the safety devices are working properly

Wear suitable ear, eye, and face protection

Select a powder level that will do the work without excessive force



HILTI	H 875182
QUALIFIED OPERATOR Powder Actuated Tools	DATE: <u>22 Jan 92</u>
<u>336528074</u> ID/CARD NO.	<u>6 JUN 56</u> DATE OF BIRTH
This certifies that <u>MA. JACOB L. ANDRUSOAL</u> NAME OF OPERATOR (PRINT)	
has received the prescribed training in the operation of powder operated tools manufactured by HILTI, INC.	
<u>HILTI</u> MAKE	<u>DX 36 M, DX 350, DX 451</u> MODELS
<u>Will RA</u> SIGNATURE OF AUTHORIZED INSTRUCTOR	<u>36091</u> INSTRUCTOR CARD NO.
I have received the instruction in the safe operation and maintenance of powder actuated fastening tools of the makes and models specified and agree to conform to all rules and regulations governing their use.	
PRIMI CONSTRUCTION INC.	SIGNATURE: <u>Michael J. Fisher</u> Revocation of card - Failure to comply with any of the rules and regulations for safe operation of powder actuated fastening tools shall be cause for the immediate revocation of this card, and it must be surrendered upon demand of the proper authority.

Fatal Fact

Employee killed when struck in head by a nail fired from a powder actuated tool.

Tool operator was attempting to anchor a plywood form in preparation for pouring a concrete wall

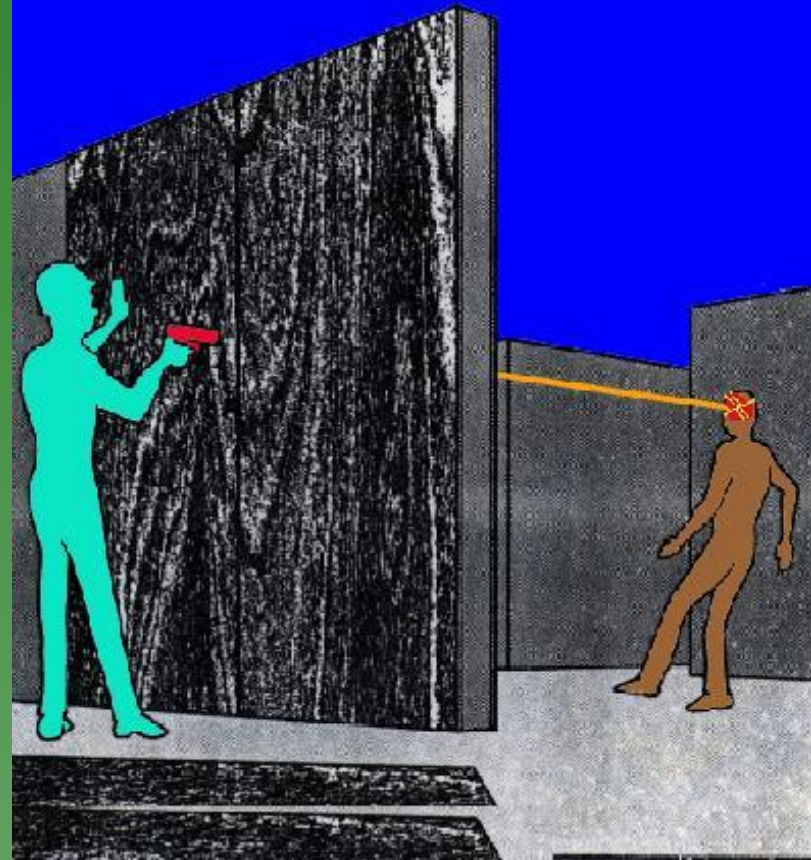

Easily Penetrated Material

Avoid driving into materials easily penetrated unless materials are backed by a substance that will prevent the pin or fastener from passing through

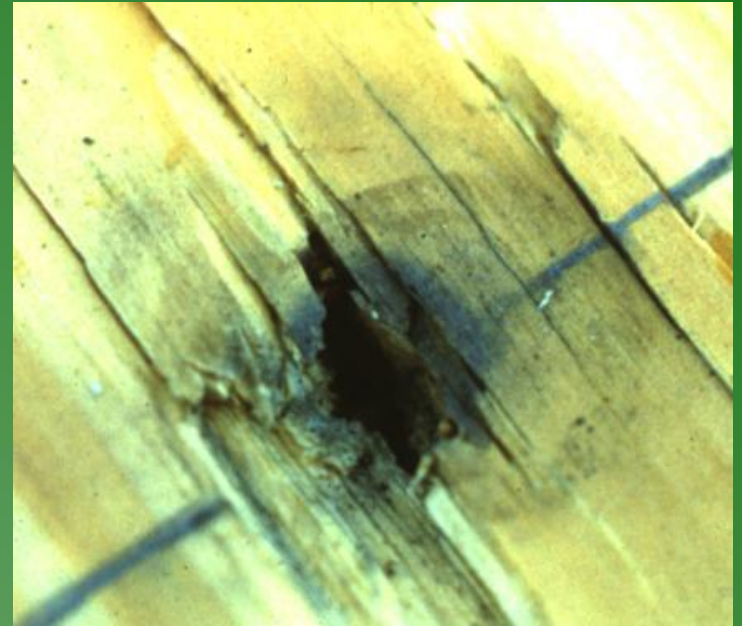

Also, don't drive fasteners into very hard or brittle material that might chip or splatter, or make the fasteners ricochet

Powder-Actuated Tool Safety Tips

- Don't use in explosive or flammable atmosphere
- Inspect tool before use to ensure:
 - it is clean,
 - that moving parts operate freely
 - the barrel is free from obstructions and has the proper shield, guard, and attachments
- Don't load the tool unless using immediately
- Don't leave a loaded tool unattended
- Keep hands clear of the barrel end
- Never point the tool at anyone
- Store unloaded in a locked box

Jacks

To set up a jack, ensure:

- The base is on a firm, level surface
- It's centered
- The jack head is placed against a level surface
- You apply the lift force evenly

Lubricate and inspect jacks regularly



Jacks - Capacity



The manufacturer's rated capacity must be marked on all jacks and must not be exceeded

All jacks must have a stop indicator that is not exceeded

Jacks - Blocking

Immediately block the load after it is lifted. Put a block under the base of the jack when the foundation is not firm, and place a block between the jack cap and load if the cap might slip.

Photo - handyman jack is provided a firm base by using the railroad tie. The load is cribbed to prevent it from falling.



Summary

Hazards are usually the result of improper tool use or not following one or more of these protection techniques:

- Inspecting the tool before use
- Using PPE (Personal Protective Equipment)
- Using guards
- Properly storing the tool
- Using safe handling techniques