

1926 Subpart P

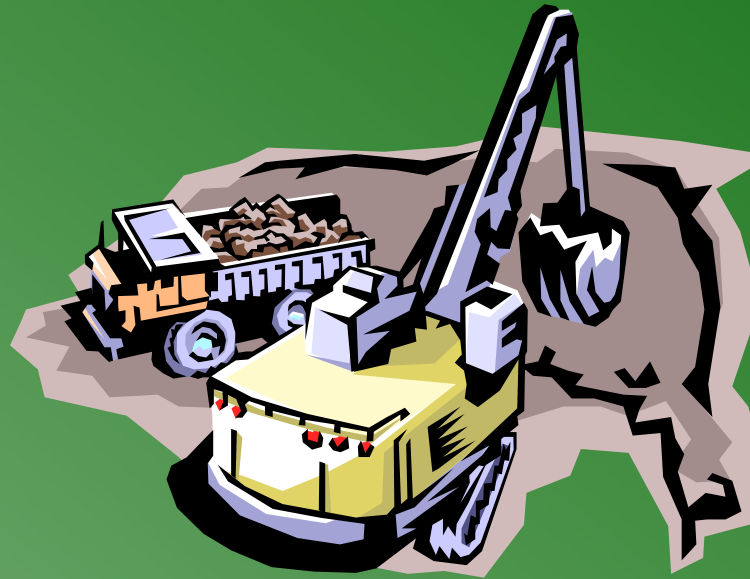

Excavations

Introduction

- Excavating is recognized as one of the most hazardous construction operations
- Fatality rate for excavations is twice that of construction as a whole
- Cave-ins number one hazard

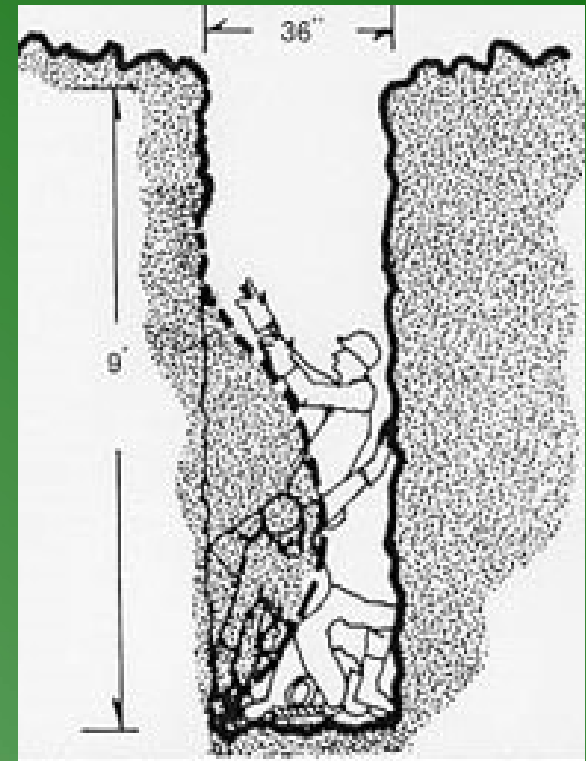

Subpart P - Excavations (1926.650 - 652)

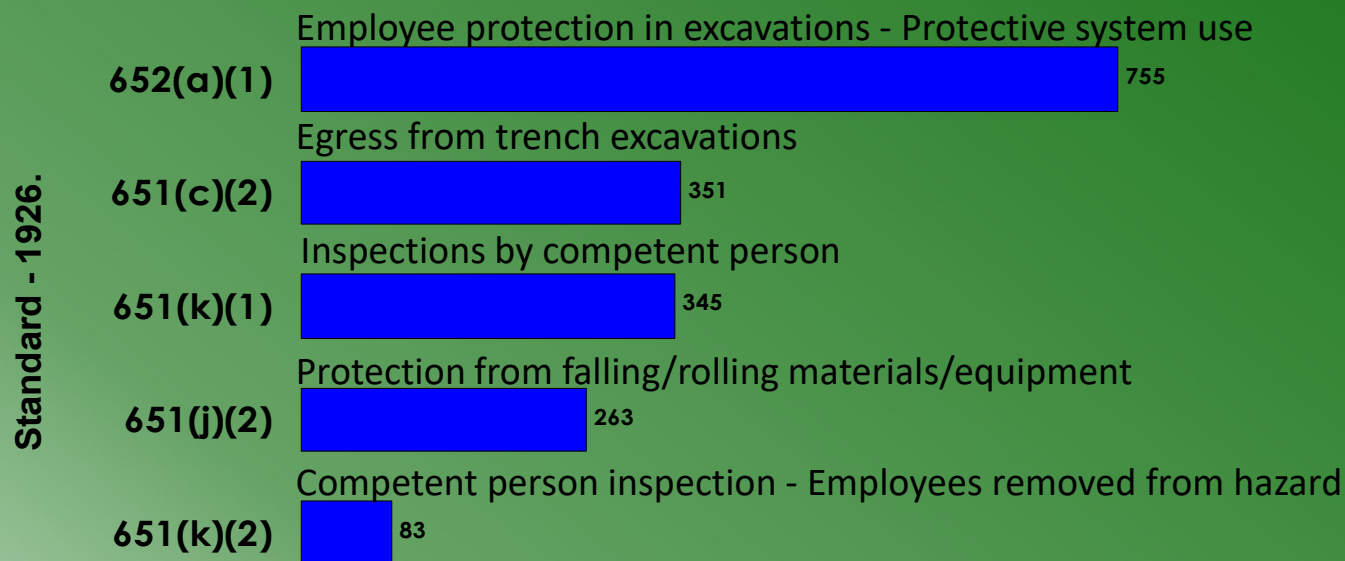
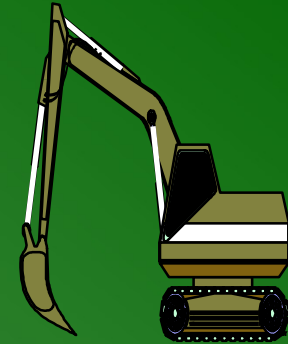

Introduction

- Cave-ins are much more likely to result in worker fatalities than other excavation-related accidents.
- 90% of all violations related to lack of cave-in protection involved manhole installations
- During inspections where these violations were cited, the excavations were nearly vertical



§1926.650 Scope & application, definitions

- Accepted engineering practices
- Aluminum hydraulic shoring
- Bell-bottom pier
- Benching
- Cave-in
- Competent person
- Cross braces
- Excavation
- Faces or sides
- Failure
- Hazardous atmospheres
- Kick-out
- Protective systems
- Ramp
- Sheeting
- Shield
- Shoring
- Sloping
- Stable rock
- Structural ramp
- Trench

Definitions

- "Excavation" means any man-made cut, cavity, trench, or depression in an earth surface, formed by earth removal.
- "Trench (Trench excavation)" means a narrow excavation (in relation to its length) made below the surface of the ground.
 - In general, the depth is greater than the width, but the width of a trench (measured at the bottom) is not greater than 15 feet (4.6 m).
 - **If forms or other structures are installed or constructed in an excavation so as to reduce the dimension measured from the forms or structure to the side of the excavation to 15 feet (4.6 m) or less (measured at the bottom of the excavation), the excavation is also considered to be a trench.**

Definitions

- Competent person for excavations:
 - Training, experience, and knowledge of:
 - soil analysis;
 - use of protective systems; and
 - requirements of 29 CFR Part 1926 Subpart P.
 - Ability to detect:
 - conditions that could result in cave-ins;
 - failures in protective systems;
 - hazardous atmospheres; and
 - other hazards including those associated with confined spaces.
 - Authority to take prompt corrective measures to eliminate existing and predictable hazards and to stop work.



Exemptions

- **House foundations/excavations if:**

- The house foundation/basement excavation is less than 7-1/2 feet deep or is benched for at least 2 feet horizontally for every 5 feet of depth
- Horizontal width at bottom of trench is at least 2 feet
- No adverse environmental conditions present
- No heavy equipment operating in area or other excessive vibration source
- All surcharge loads at least as far away from excavation as excavation is deep
- Minimum number of employees and amount of time in excavation



§1926.651 Specific Excavation Requirements

- Surface encumbrances
- Underground installations
- Access and egress
- Exposure to vehicular traffic
- Exposure to falling loads
- Warning system for mobile equipment
- Hazardous atmospheres
- Protection from hazards associated with water accumulation
- Stability of adjacent structure
- Protection of employees from loose rock or soil
- Inspections
- Fall protection

§1926.651 Specific Excavation Requirements

- Remove all surface encumbrances
- Determine location of all underground utilities *before opening excavation*
- Use safe means to determine exact locations & protect underground utilities



§1926.651 Specific Excavation Requirements

- **Access & Egress:**

- Ramps for egress designed by CP in structural design & constructed according to design
- Segments of ramps must be connected without creating a tripping hazard
- Uniform thickness



§1926.651 Specific Excavation Requirements

- Stairway, ladder, ramp or other safe means of egress shall be located in trench excavations that are 4 feet or more in depth to require no more than **25 feet** of lateral travel for employees.

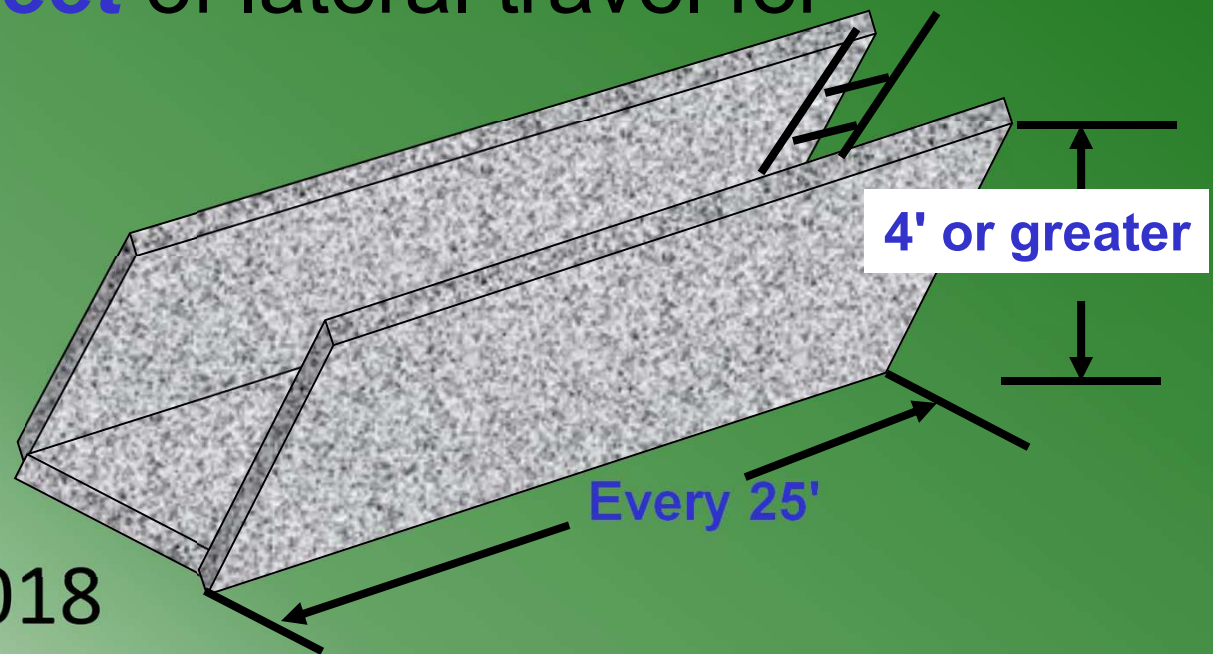

§1926.651 Specific Excavation Requirements

- In traffic areas reflective vests required
- No workers underneath loads handled by lifting or digging equipment.
- Barricades, stop logs or hand signals for mobile equipment operating near excavations



§1926.651 Specific Excavation Requirements

- In excavations 4 feet or more where hazardous atmospheres are likely to exist must test atmosphere before entering



- Ventilation or PPE must be used as required
- Retest atmospheres as necessary
- Rescue equipment available

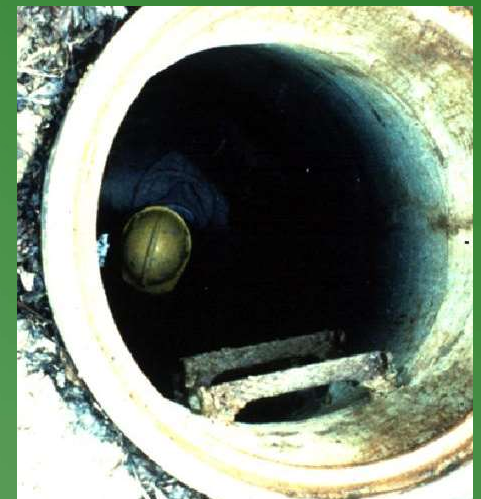

§1926.651 Specific Excavation Requirements

Precautions required before working for water in excavations

CP must monitor control measures

If diverting surface water must take steps to prevent water from entering trench



§1926.651 Specific Excavation Requirements

- Structures adjacent to excavations must be supported if stability is affected
- No entry where workers below adjacent footings unless shored, or stable rock, or approved by PE
- No undermining pavements unless supported

§1926.651 Specific Excavation Requirements

- Protect workers from loose rock & soil
- Spoil at least 2 feet away, or retained, or both



§1926.651 Specific Excavation Requirements

- Daily inspections made by Competent Person if workers in trench:
- Prior to start of work and repeated as necessary
- After every rainstorm
- After any hazard increasing occurrence
- Employees removed until hazards are until safe

§1926.651 Specific Excavation Requirements



- Walkways for employees crossing excavations
- Guardrails for walkways six feet above lower levels
- Wells, pits, shafts, barricaded & covered
- Upon completion filled

1926.652 - Requirements for protective systems

- Protection of employees in excavations
- Design of sloping and benching systems
- Design of support systems, shield systems, and other protective systems
- Materials and equipment
- Installation and removal



1926.652 - Requirements for protective systems

- Provide full worker protection from cave-ins except:
 - Excavation completely in stable rock
 - Less than five feet deep & Competent Person determines no potential for cave-in



1926.652 - Requirements for protective systems

- Protective systems shall have the capacity to resist without failure all loads that are intended or could reasonably be expected to be applied or transmitted to the system.

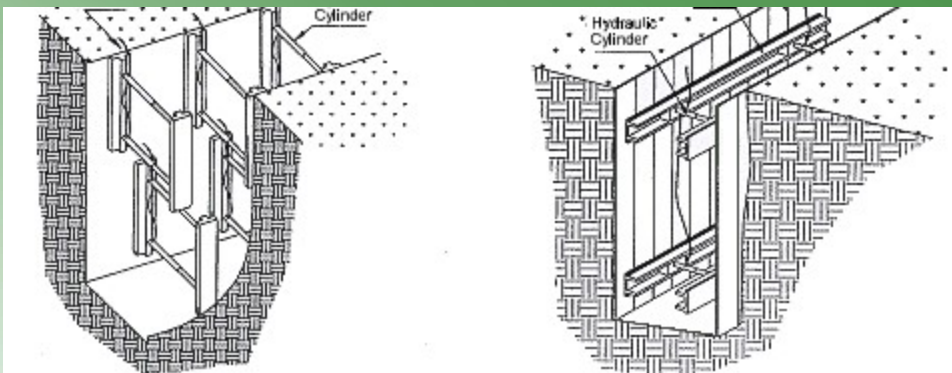

1926.652 - Requirements for protective systems

- Four choices for sloping:
 - Slope for type 'C'
 - Use sloping choices from Appendix B
 - Tabulated data determined by a Professional Engineer
 - Designed by a Professional Engineer

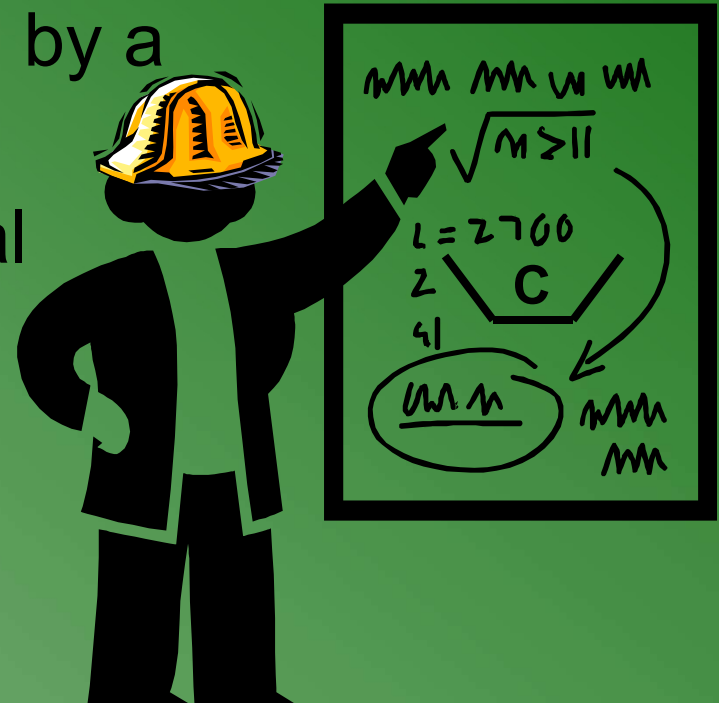

1926.652 - Requirements for protective systems

- Materials for protective systems free from damage & defects
- Used according to manufacturers specifications
- If damaged CP must determine suitability for continued use



1926.652 - Requirements for protective systems

- Support system members securely connected together
- Installed & removed to assure employee safety
- Support systems not subjected to loads exceeding their capacity



1926.652 - Requirements for protective systems

- Removal of support systems from bottom up
- Backfilling progresses with the removal of shoring

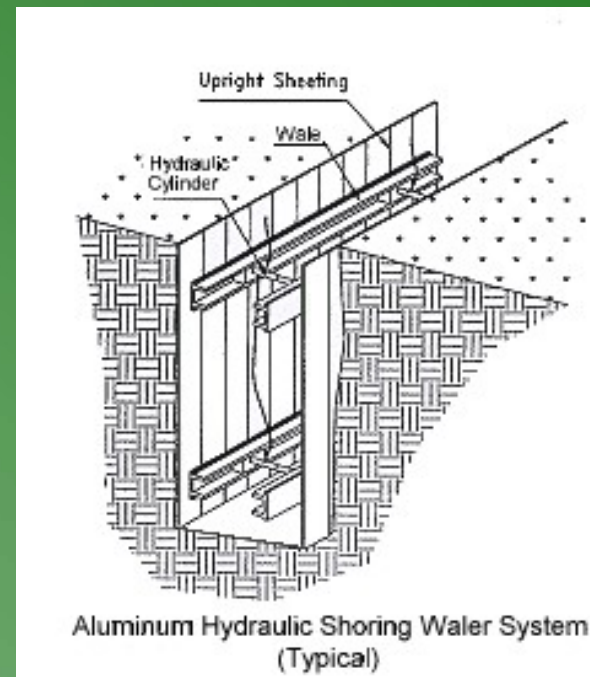

1926.652 - Requirements for protective systems

- Excavation of up to 2 feet underneath support system allowed only if:
 - System designed for support of full depth
 - No evidence of loss of soil loss behind or below

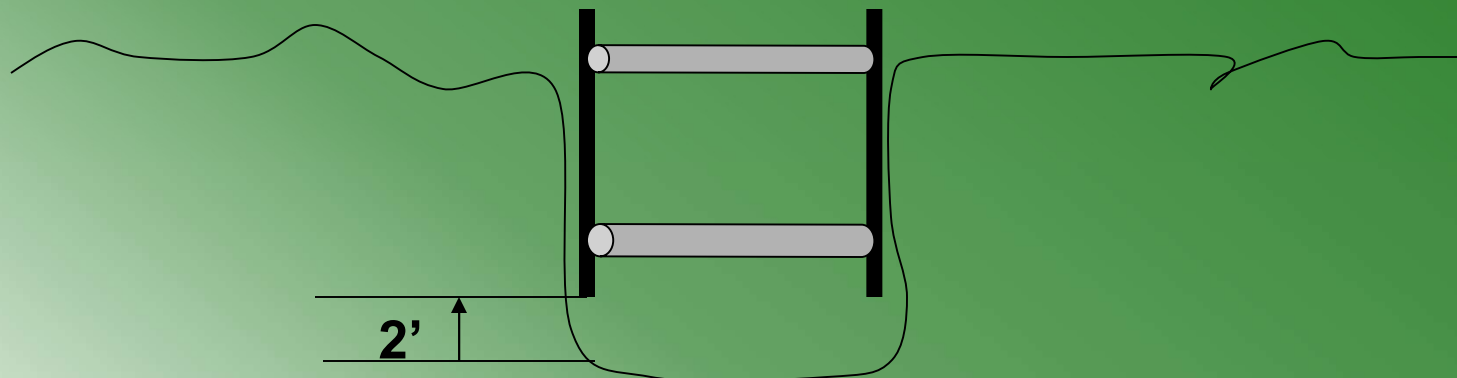

1926.652 - Requirements for protective systems

- No working on sloped or benched faces unless employees below are protected



1926.652 - Requirements for protective systems

- Shield systems not subject to loads exceeding their capacity
- Installed to restrict lateral movement
- Employee protection provided while entering/exiting shields
- No employees in trench during installation or removal of shields

SHORING SHIELD* CERTIFICATION

Model No. 1926.652

Serial No. 3-2830

Rated Shield Capacity:

Static PSF (lbs. per sq. ft.) 1100

Hydraulic PSF (lbs. per sq. ft.) 1700

▼ CAUTION ▼

MANUFACTURED IN COMPLIANCE WITH O.S.H.A. REGULATIONS AS STATED IN THE FEDERAL REGISTER THIS SHIELD MUST BE USED IN STRICT ACCORDANCE WITH O.S.H.A. REGULATIONS AND MANUFACTURER'S TABULATED DATA.

CONSULT A QUALIFIED ENGINEER TO DETERMINE LATERAL EARTH PRESSURES (PSF) PRIOR TO EACH USE OF THIS SHIELD. DO NOT EXCEED THE RATED CAPACITY.

STATIC CAPACITY IS EFFECTIVE WHEN ALL STEEL TUBE CROSS BRACES ARE PINNED AND SHIELD IS NOT PRESSURIZED AGAINST TRENCH WALLS.

HYDRAULIC CAPACITY IS EFFECTIVE WHEN THE HYDRAULIC CYLINDERS ARE PRESSURIZED AND SHIELD PRESSES FIRMLY AGAINST TRENCH WALLS.

ALL HOISTING EQUIPMENT FOR HANDLING OF THIS SHIELD IS THE RESPONSIBILITY OF THE USER.



1926 Subpart P Appendix A - Soil Classification

- A method of categorizing soil and rock deposits in a hierarchy of:
 - Stable Rock,
 - Type A,
 - Type B, and
 - Type C



1926 Subpart P Appendix A - Soil Classification

- "Stable rock" means natural solid mineral matter that can be excavated with vertical sides and remain intact while exposed.
- "Type A" means cohesive soils with an unconfined, compressive strength of 1.5 ton per square foot (tsf) or greater.
- Examples of cohesive soils are: clay, silty clay, sandy clay, clay loam.



1926 Subpart P Appendix A - Soil Classification

- However, no soil is Type A if:
 - (i) The soil is fissured; or
 - (ii) The soil is subject to vibration from heavy traffic, pile driving, or similar effects; or
 - (iii) The soil has been previously disturbed; or
 - (iv) The soil is part of a sloped, layered system where the layers dip into the excavation on a slope of four horizontal to one vertical (4H:1V) or greater;

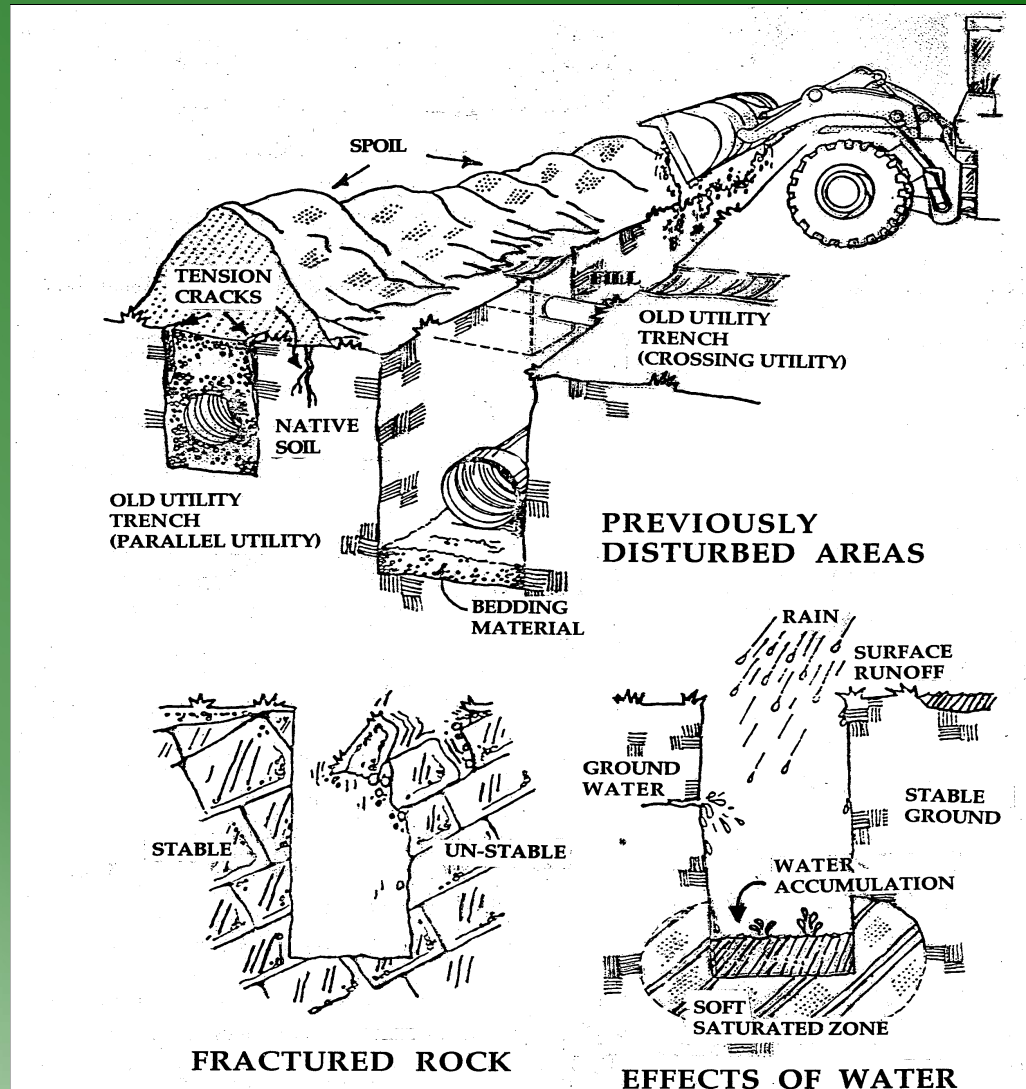

1926 Subpart P Appendix A - Soil Classification

- "Type B" means:
 - (i) Cohesive soil with an unconfined compressive strength greater than 0.5 tsf but less than 1.5 tsf ; or
 - (ii) Granular non-cohesive soils including: angular gravel (similar to crushed rock), silt, silt loam, sandy loam and,
 - (iii) Previously disturbed soils except those which would otherwise be classed as Type C soil,
 - (iv) Type A, but is fissured or subject to vibration; or
 - (v) Dry rock that is not stable

1926 Subpart P Appendix A - Soil Classification

- "Type C" means:
 - (i) Cohesive soil with an unconfined compressive strength of 0.5 tsf (48 kPa) or less; or
 - (ii) Granular soils including gravel, sand, and loamy sand; or
 - (iii) Submerged soil or soil from which water is freely seeping; or
 - (iv) Submerged rock that is not stable

Soils - Types & Particle Size

- **Gravel**



- larger than 2 millimeters

- **Sand**



- Smaller than 2 millimeters but larger than 0.075 millimeters

- **Silt**



- Smaller than 0.075 millimeters but larger than 0.002 millimeters

- **Clay**



- Smaller than 0.002 millimeters

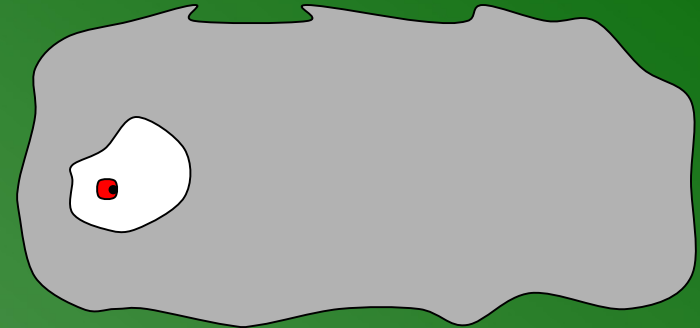

Additional soil classification

- LAYERED GEOLOGICAL STRATA:
 - Where soils are configured in layers, i.e., where a layered geologic structure exists, the soil must be classified on the basis of the soil classification of the weakest soil layer.
 - Each layer may be classified individually if a more stable layer lies below a less stable layer, i.e., where a Type C soil rests on top of stable rock.

USDA TEXTURAL SOILS CLASSIFICATION SYSTEM

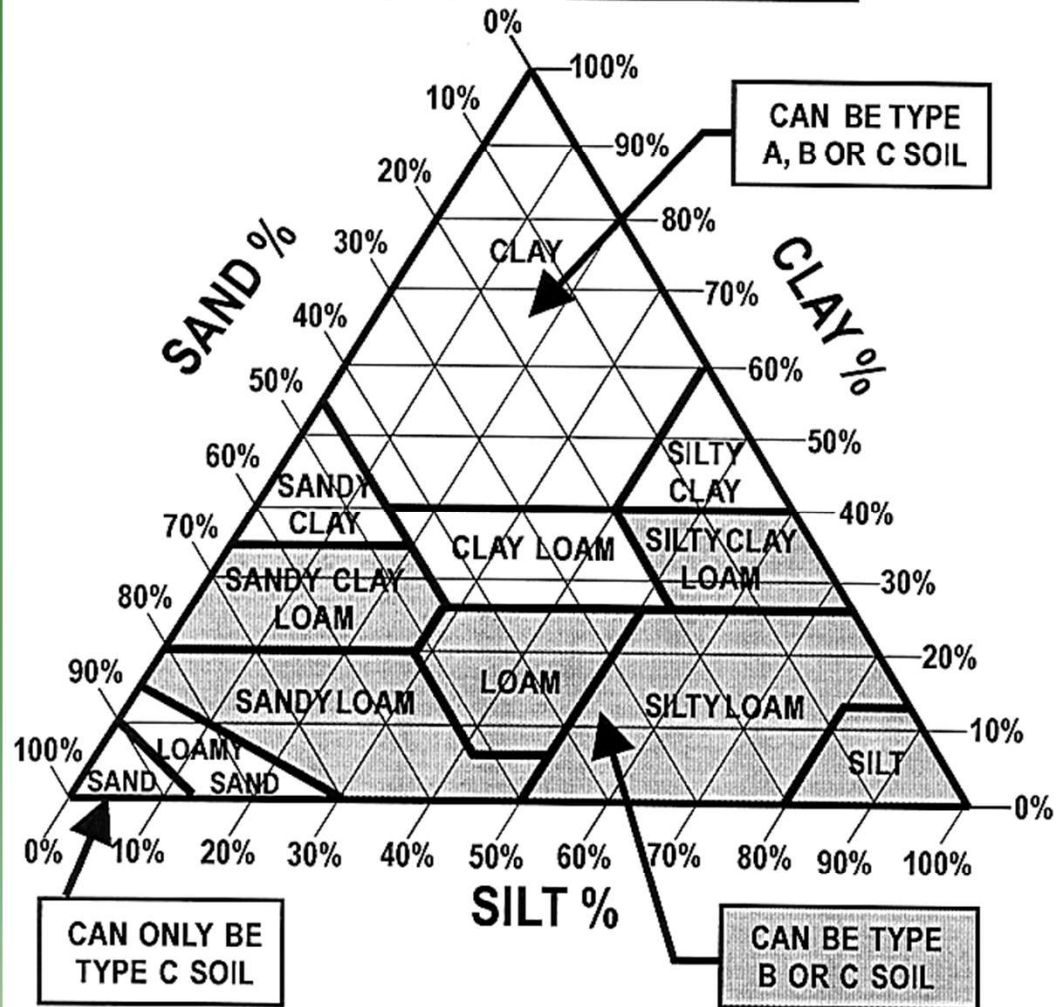

1926 Subpart P Appendix A - Soil Classification

- "Unconfined compressive strength" means the load per unit area at which a soil will fail in compression.
- It can be determined by laboratory testing, or estimated in the field using a pocket penetrometer, by thumb penetration tests, and other methods.

1926 Subpart P Appendix A - Soil Classification

- "Wet soil" means soil that contains significantly more moisture than moist soil, but in such a range of values that cohesive material will slump or begin to flow when vibrated.
- Granular material that would exhibit cohesive properties when moist will lose those cohesive properties when wet.

1926 Subpart P Appendix A - Soil Classification

- Each soil and rock deposit shall be classified by a competent person as Stable Rock, Type A, Type B, or Type C
- The classification of the deposits shall be made based on the results of at least one visual and at least one manual analysis.

Visual Tests

- To determine qualitative information regarding the excavation site consider:
 - the soil adjacent to the excavation;
 - the soil forming the sides of the open excavation;
 - the soil taken as samples from excavated material.



Visual Tests

- Observe the side of the opened excavation and the surface area adjacent to the excavation.
- Crack-like openings such as tension cracks could indicate fissured material.
- If chunks of soil spall off a vertical side, the soil could be fissured.
- Small spalls are evidence of moving ground and are indications of potentially hazardous situations.

Visual Tests

- Observe the area adjacent to the excavation and the excavation itself for evidence of existing utility and other underground structures, and to identify previously disturbed soil.
- Observed the opened side of the excavation to identify layered systems. Examine layered systems to identify if the layers slope toward the excavation. Estimate the degree of slope of the layers.

Visual Tests

- Observe the area adjacent to the excavation and the sides of the opened excavation for evidence of surface water, water seeping from the sides of the excavation, or the location of the level of the water table.
- Observe the area adjacent to the excavation and the area within the excavation for sources of vibration that may affect the stability of the excavation face.

Observe samples of soil that are excavated and soil in the sides of the excavation. Estimate the range of particle sizes and the relative amounts of the particle sizes. Soil that is primarily composed of fine-grained material material is cohesive material. Soil composed primarily of coarse-grained sand or gravel is granular material. The evaluator also considers the effects of vibration.

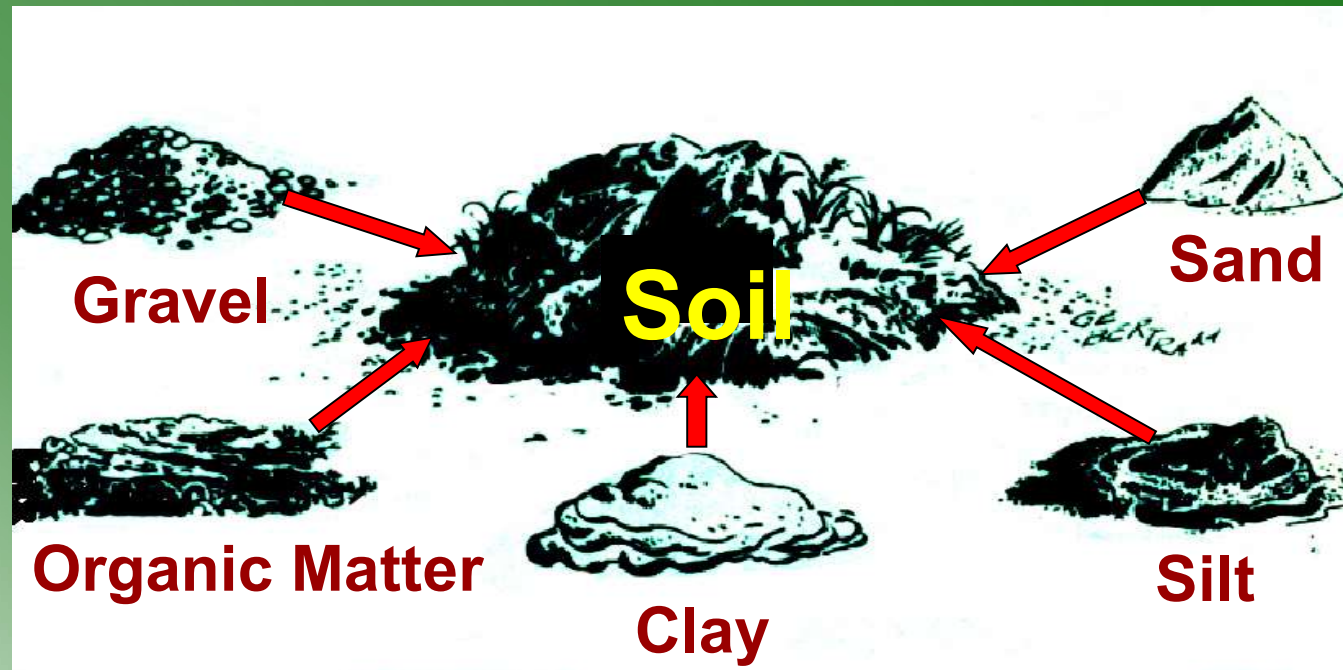

Soil Characteristics

- Soil that remains in clumps when excavated is cohesive.
- Soil that breaks up easily and does not stay in clumps is granular.
- Cemented soil is highly cohesive, will not break with finger pressure
- Cohesive soil high in clay, does not break apart into particles, can be formed

Soil Field Tests

- Thumb test
- Plasticity
- Pocket penetrometer
- Torvane shear
- Sedimentation

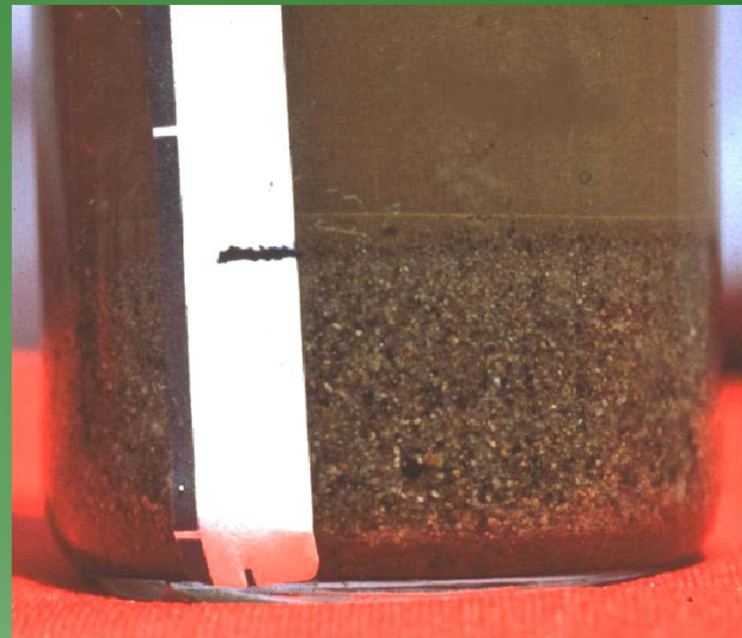

Thumb test

- ASTM test designation D 2488
- Retrieve a large clump of undisturbed spoil
- Attempt to penetrate the soil with the tip of the thumb
- Type A soil can be penetrated only with great force
- Type B will penetrate to the full length of the thumb nail
- Type C will penetrate easily several inches and can be molded by light finger pressure

Plasticity



- Roll a moist sample of spoil into a ball
- Roll the ball out into a 1/8" by 2 " thread
- If this can be done, hold it on end
- If it remains suspended without tearing the soil is cohesive

Pocket penetrometer

- POCKET PENETROMETER.
Penetrometers are direct-reading, spring-operated instruments used to determine the unconfined compressive strength of saturated cohesive soils.
- Once pushed into the soil, an indicator sleeve displays the reading.
- The instrument is calibrated in either tons per square foot (tsf) or kilograms per square centimeter (kPa).
- **However, Penetrometers have error rates in the range of $\pm 20-40\%$.**

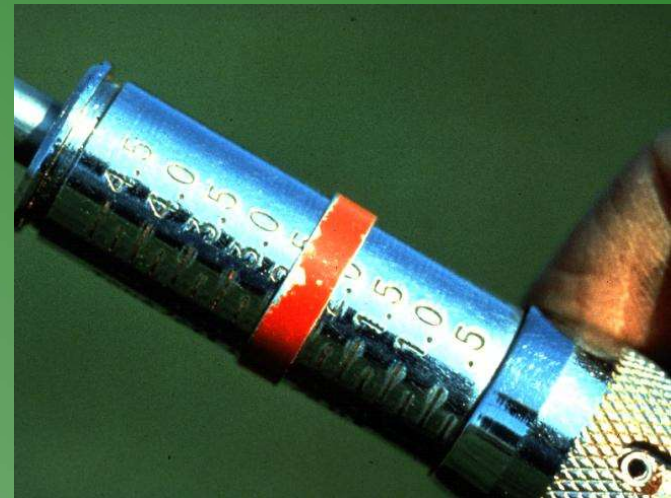
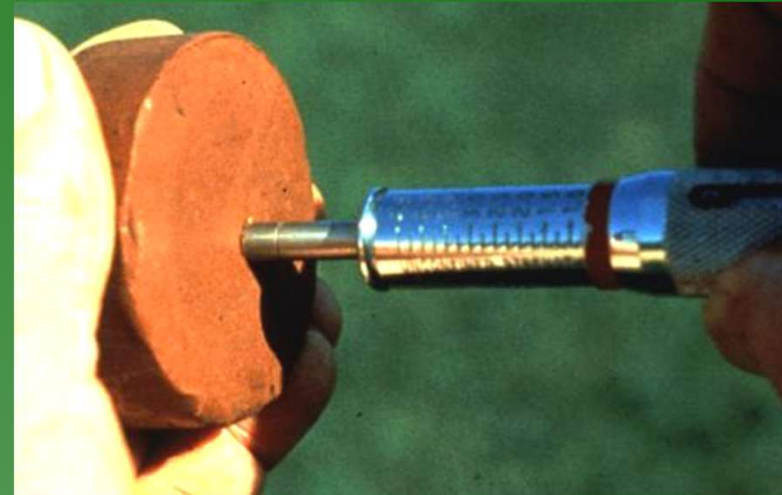

Pocket penetrometer

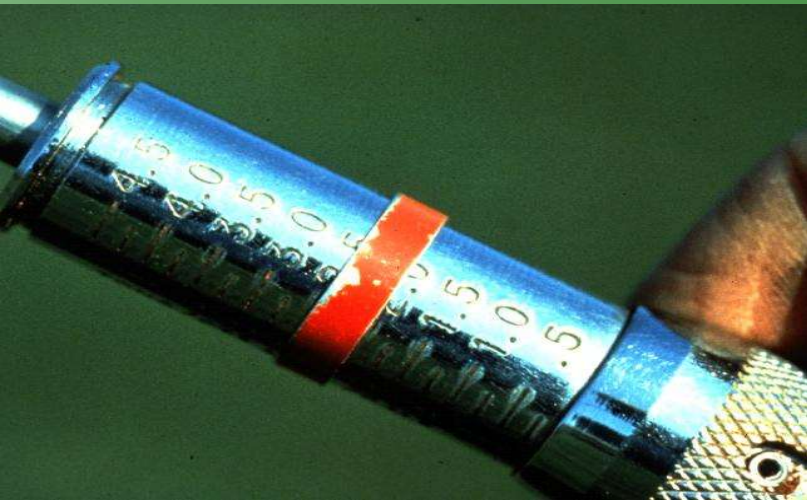
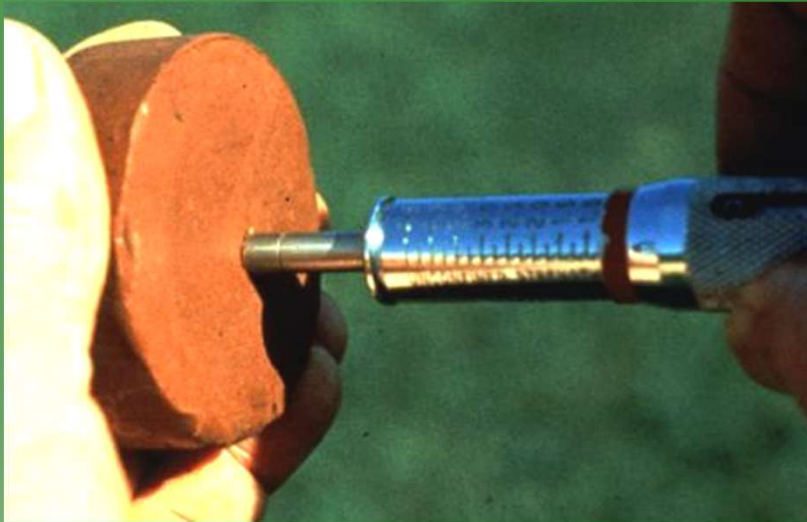

- Push red ring on the barrel all the way toward the handle
- Push shaft into the soil up to the red ring
- Hold barrel so as to not to interfere with the spring inside the barrel
- Read the unconfined compressive strength at bottom of the red slip ring

Torvane Shear

- Select fresh clod or block of undisturbed soil from spoil pile
- Cut a smooth surface on the clod
- Insert vanes of device into the soil
- Retract vanes to show foot imprint
- Set indicator at zero
- Hold device firmly against soil and twist in clockwise manner until soil fails in shear



Torvane Shear

- Select fresh clod or block of undisturbed soil from spoil pile
- Cut a smooth surface on the clod
- Insert vanes of device into the soil
- Retract vanes to show foot imprint
- Set indicator at zero
- Hold device firmly against soil and twist in clockwise manner until soil fails in shear



The direct instrument reading must be multiplied by 2 to provide results in tons per square foot (tsf)

Consistency Term	Shear Strength, psf	Unconfined Compressive Strength, psf	Soil Type
------------------	---------------------	--------------------------------------	-----------

Very Soft	<250	<500	TYPE "C"
-----------	------	------	-----------------

Soft	250-500	500-1000
------	---------	----------

Medium	500-1000	1000-2000	TYPE "B"
--------	----------	-----------	-----------------

Stiff Stiff	1000-1500	2000-3000
	1500-2000	3000-4000

Very Stiff Hart	2000-4000	4000-8000	TYPE "A"
	>4000	>8000	



Sedimentation

- Flat bottom container at least 7 inches high
- Fill glass jar
- 5 inches of water on top of soil
- 1 1/2 inches of soil



- Place lid on jar and shake
 - Set jar down
 - Rotate slightly
 - Larger particles settle out immediately
 - Wait 30 seconds
 - Mark jar
 - Silt after several minutes
 - Fine clays in an hour
 - Make second mark

**COHESIVE SOILS
UNCONFINED
COMPRESSIVE
STRENGTH**

- C 0 - 0.5 TSF**
- B 0.5- 1.5 TSF**
- A 1-5 UP TSF**

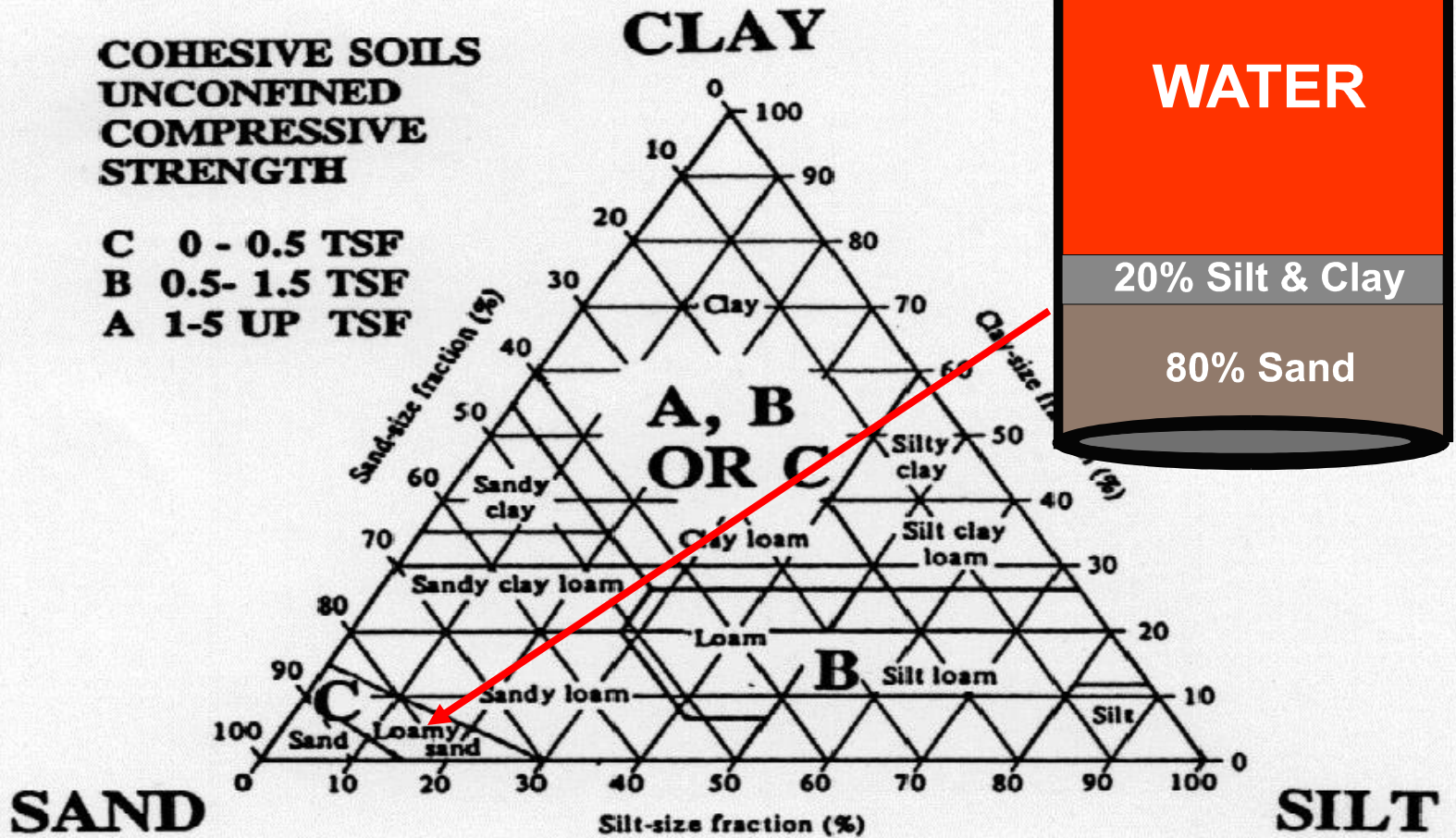

Visual tests & soil mechanics

- The evaluator should also look for signs of bulging, boiling, or sluffing, as well as for signs of surface water seeping from the sides of the excavation or from the water table.
- In addition, the area adjacent to the excavation should be checked for signs of foundations or other intrusions into the failure zone, *and the evaluator should check for surcharging and the spoil distance from the edge of the excavation.*

Soil Mechanics

- A number of stresses and deformations can occur in an open cut or trench.
- For example, increases or decreases in moisture content can adversely affect the stability of a trench or excavation.
- The following diagrams show some of the more frequently identified causes of trench failure.

Soil Mechanics

- TENSION CRACKS. Tension cracks usually form at a horizontal distance of 0.5 to 0.75 times the depth of the trench, measured from the top of the vertical face of the trench.

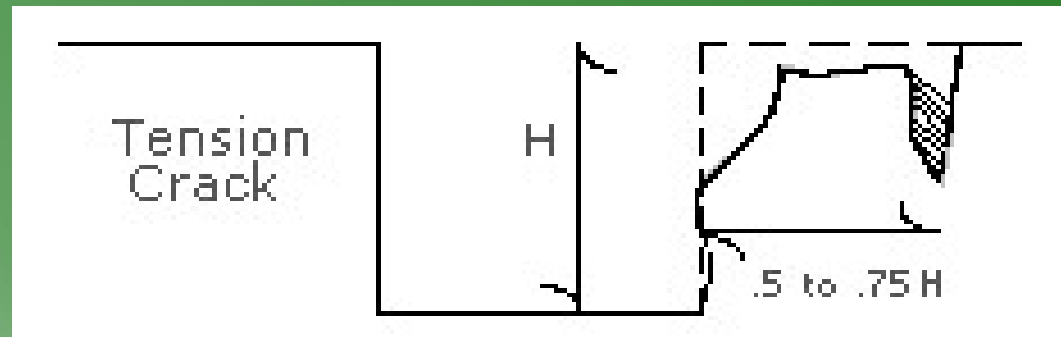

Soil Mechanics

- SLIDING or sluffing may occur as a result of tension cracks, as illustrated below.

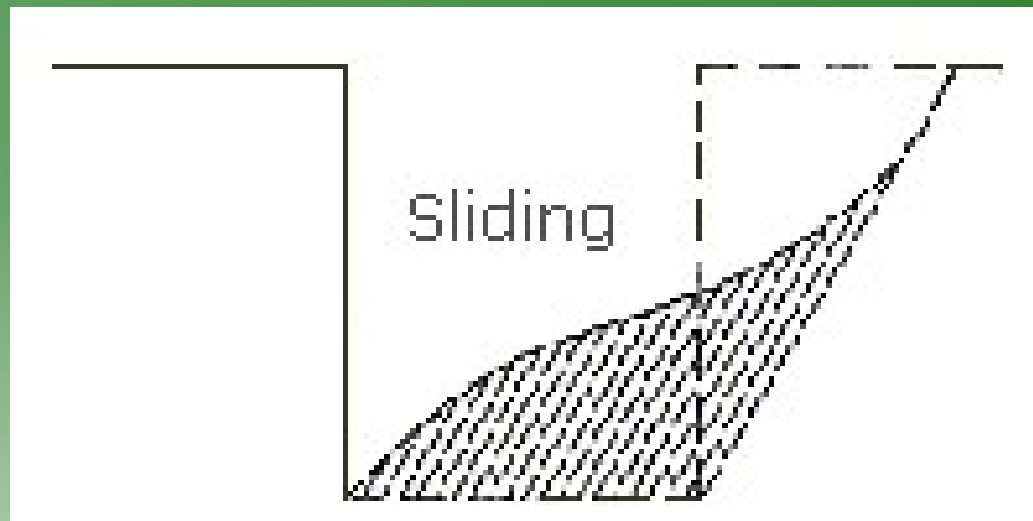

Soil Mechanics

- TOPPLING. In addition to sliding, tension cracks can cause toppling.
- Toppling occurs when the trench's vertical face shears along the tension crack line and topples into the excavation.

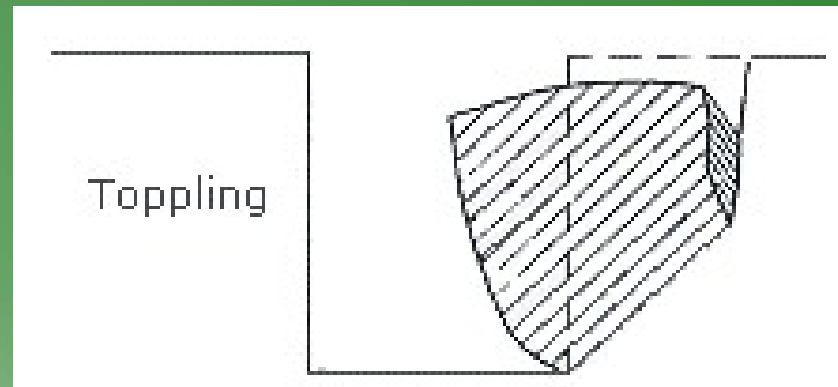

Soil Mechanics

- SUBSIDENCE AND BULGING. An unsupported excavation can create an unbalanced stress in the soil, which, in turn, causes subsidence at the surface and bulging of the vertical face of the trench.
- If uncorrected, this condition can cause face failure and entrapment of workers in the trench.

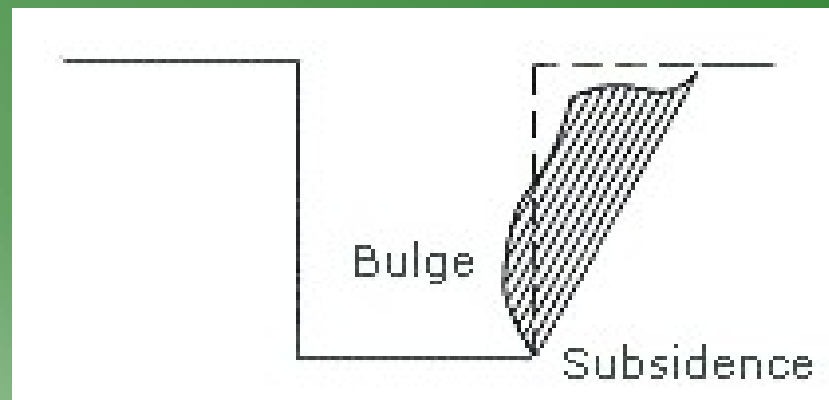

Soil Mechanics

- HEAVING OR SQUEEZING. Bottom heaving or squeezing is caused by the downward pressure created by the weight of adjoining soil. This pressure causes a bulge in the bottom of the cut, as illustrated in the drawing above. Heaving and squeezing can occur even when shoring or shielding has been properly installed.

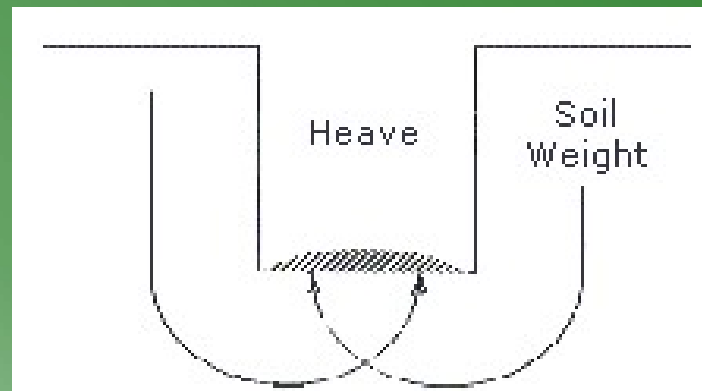

Soil Mechanics

- BOILING is evidenced by an upward water flow into the bottom of the cut. A high water table is one of the causes of boiling. Boiling produces a "quick" condition in the bottom of the cut, and can occur even when shoring or trench boxes are used.

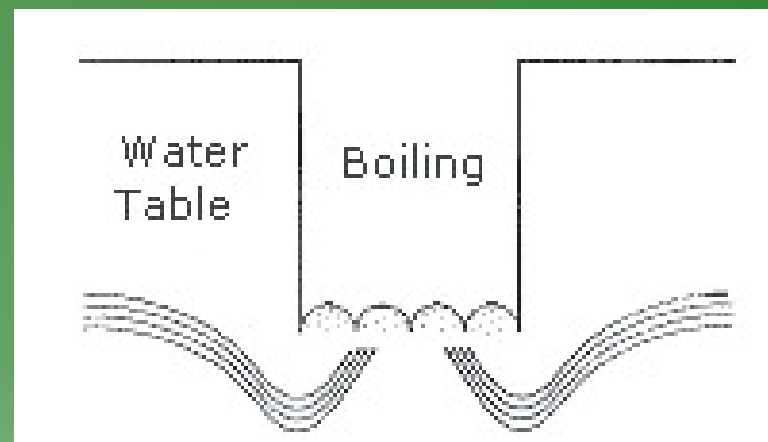

Soil Mechanics

- UNIT WEIGHT OF SOILS refers to the weight of one unit of a particular soil. *The weight of soil varies with type and moisture content.* One cubic foot of soil can weigh from 110 pounds to 140 pounds or more, and one cubic meter (35.3 cubic feet) of soil can weigh more than 3,000 pounds.

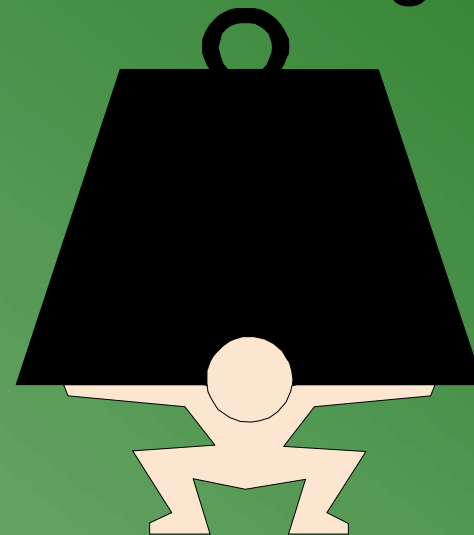

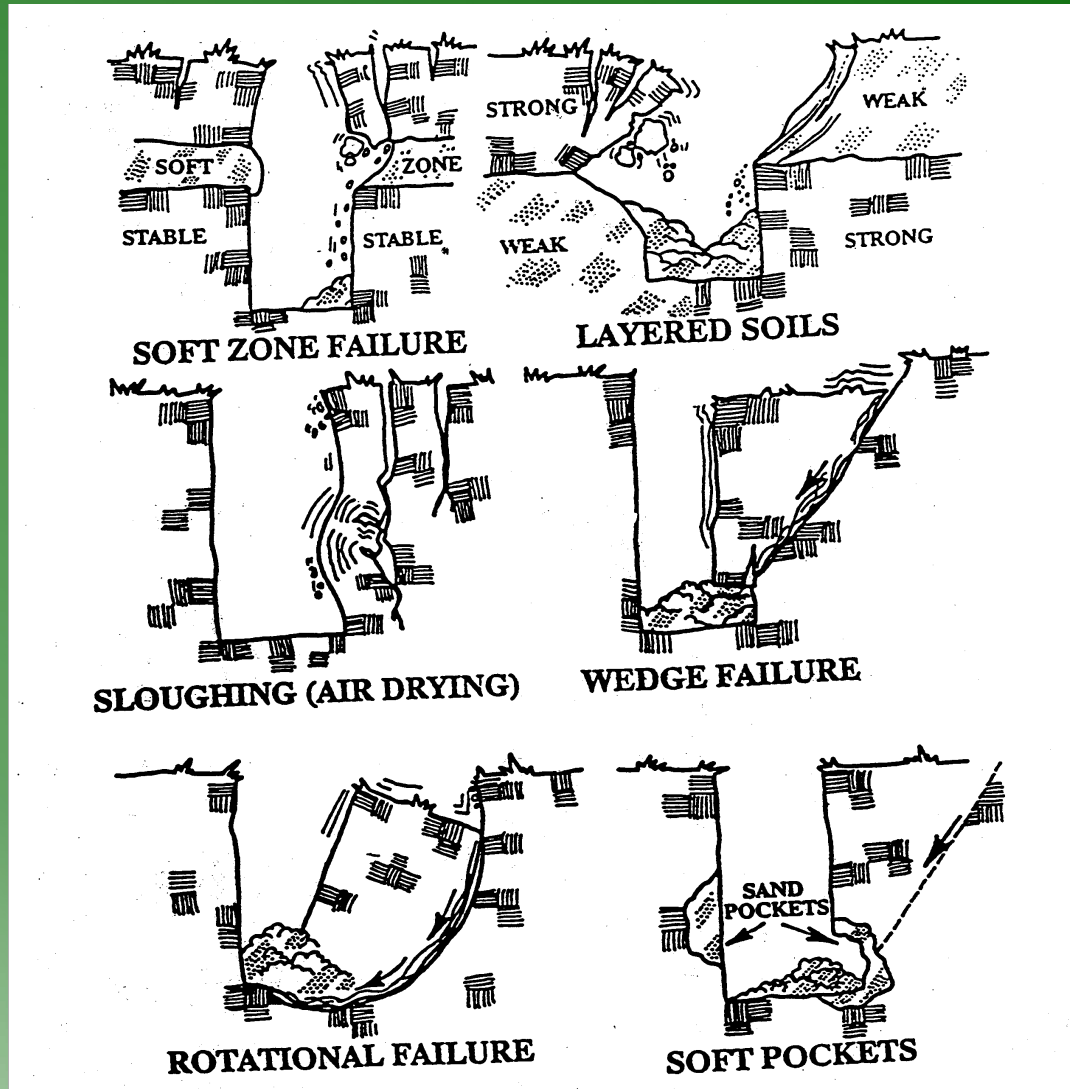

Protective Systems

- Shoring is the provision of a support system for trench faces used to prevent movement of soil, underground utilities, roadways, and foundations.
- Shoring or shielding is used when the location or depth of the cut makes sloping back to the maximum allowable slope impractical.
- Shoring systems consist of posts, wales, struts, and sheeting.
- There are two basic types of shoring, timber and aluminum hydraulic.

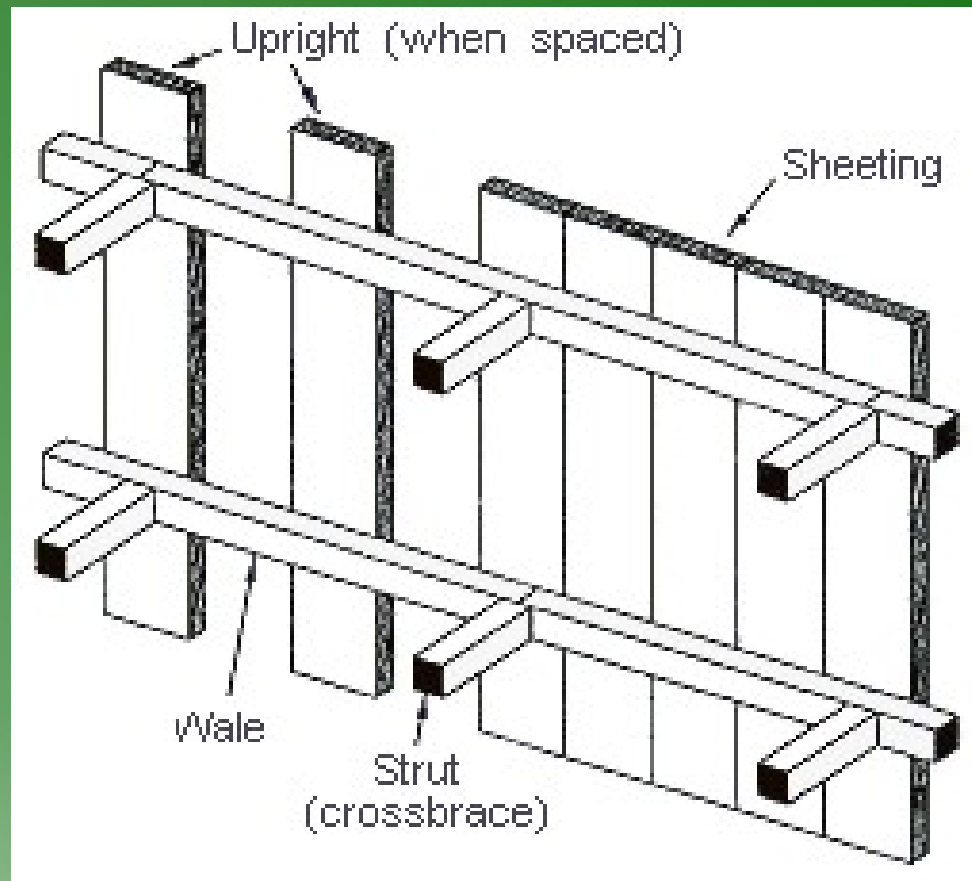

TIMBER SHORING

Protective Systems

- The trend today is toward the use of hydraulic shoring, a prefabricated strut and/or wale system manufactured of aluminum or steel.
- Hydraulic shoring provides a critical safety advantage over timber shoring because workers do not have to enter the trench to install or remove hydraulic shoring.

Protective Systems

- Other advantages of most hydraulic systems are that they:



- † Are light enough to be installed by one worker;
- † Are gauge-regulated to ensure even distribution of pressure along the trench line;
- † Can have their trench faces "preloaded" to use the soil's natural cohesion to prevent movement; and
- † Can be adapted easily to various trench depths and widths.

Protective Systems

- All shoring should be installed from the top down and removed from the bottom up.
- ***Hydraulic shoring should be checked at least once per shift*** for leaking hoses and/or cylinders, broken connections, cracked nipples, bent bases, and any other damaged or defective parts.

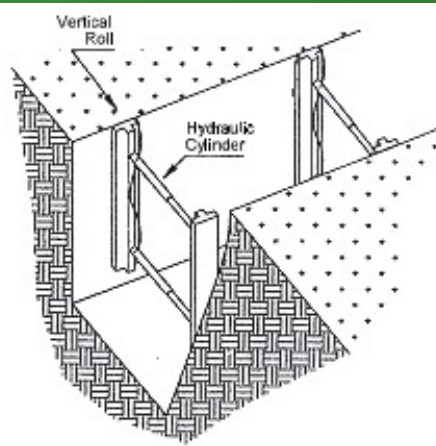

Vertical Aluminum Hydraulic Shoring
(Spot Bracing)

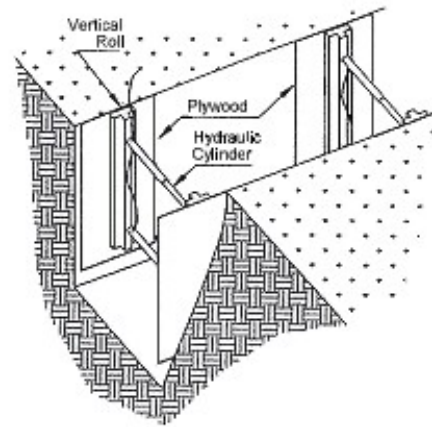

Vertical Aluminum Hydraulic Shoring
(With Plywood)

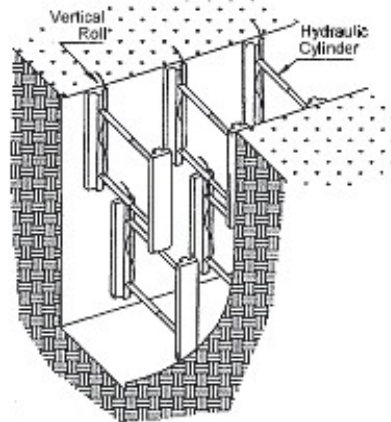

Vertical Aluminum Hydraulic Shoring
(Stacked)

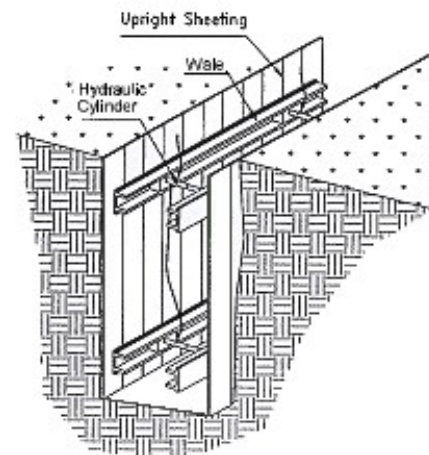

Aluminum Hydraulic Shoring Waler System
(Typical)

Protective Systems

- Screw jack systems differ from hydraulic and pneumatic systems in that the struts of a screw jack system must be adjusted manually.
- This creates a hazard because the worker is required to be in the trench in order to adjust the strut.
- In addition, uniform "preloading" cannot be achieved with screw jacks, and their weight creates handling difficulties.

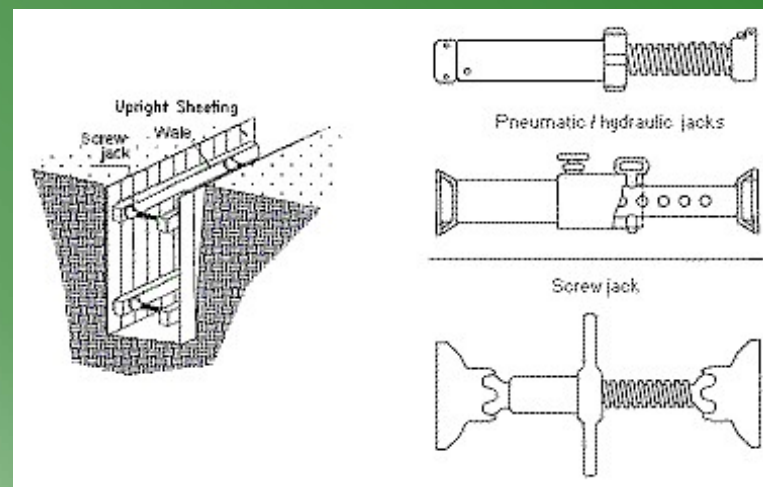

Protective Systems

- TRENCH BOXES protect workers from cave-ins and similar incidents.
- The excavated area between the outside of the trench box and the face of the trench should be as small as possible.
- The space between the trench boxes and the excavation side are backfilled to prevent lateral movement of the box.

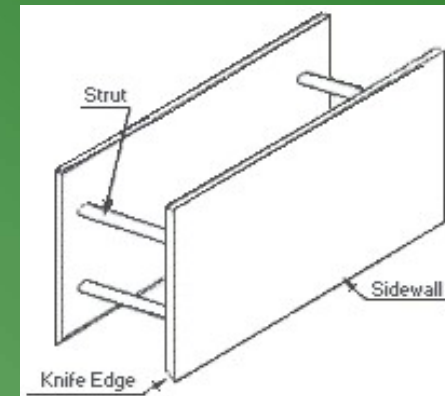
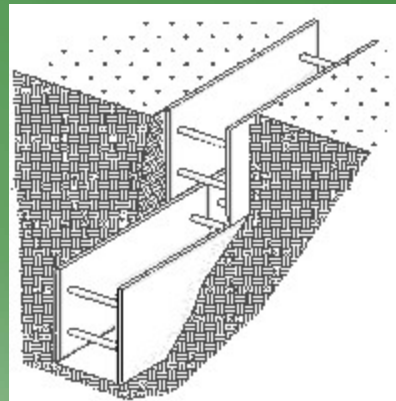



 ExperiDoc® ©2018

TYPE A SOIL
Supported or shielded
Vertically sided lower portion

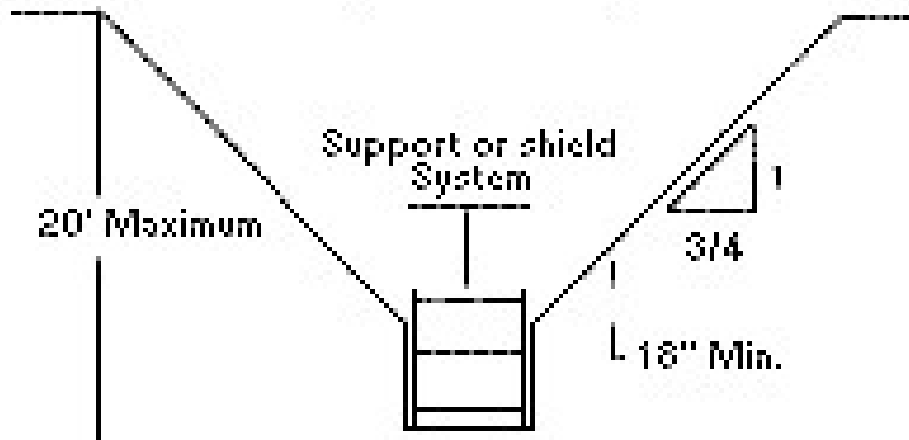

TYPE B SOIL
Supported or shielded
Vertically sided lower portion

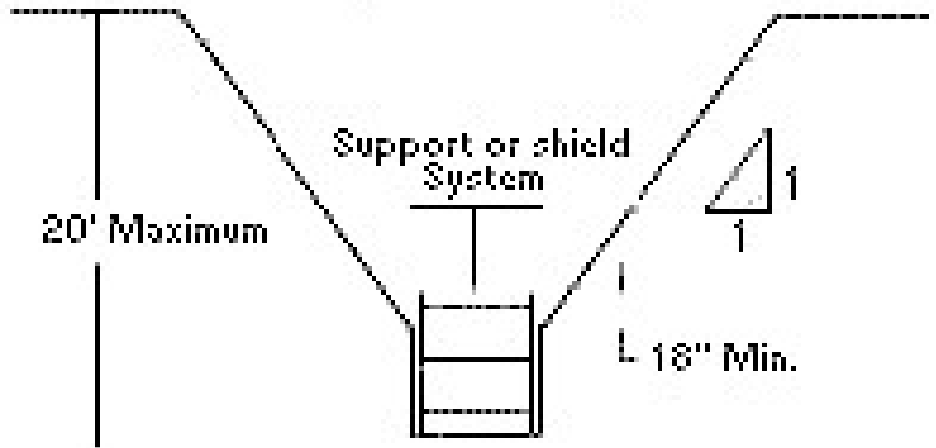

TYPE C SOIL
Supported or shielded
Vertically sided lower portion

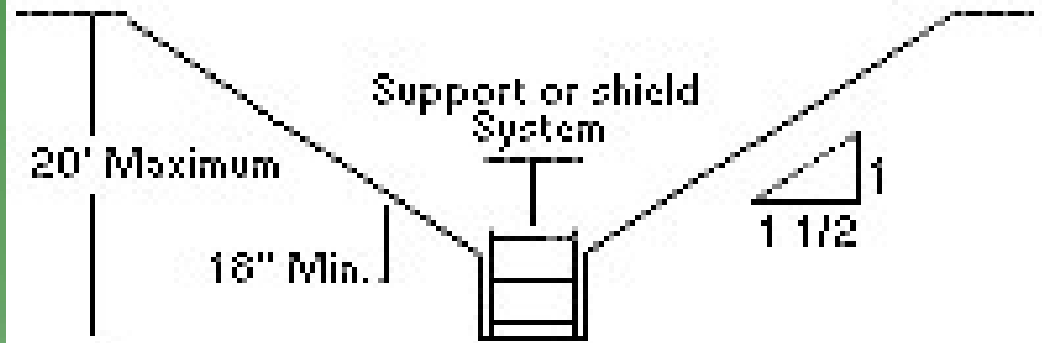

SLOPING. Maximum allowable slopes for excavations less than 20 ft (6.09 m) based on soil type and angle to the horizontal are as follows:

<i>Soil type</i>	<i>Height/Depth ratio</i>	<i>Slope angle</i>
Stable Rock	Vertical	90°
Type A	3/4:1	53°
Type B	1:1	45°
Type C	1½:1	34°
Type A (short-term) (For a maximum excavation depth of 12 ft)	½:1	63°

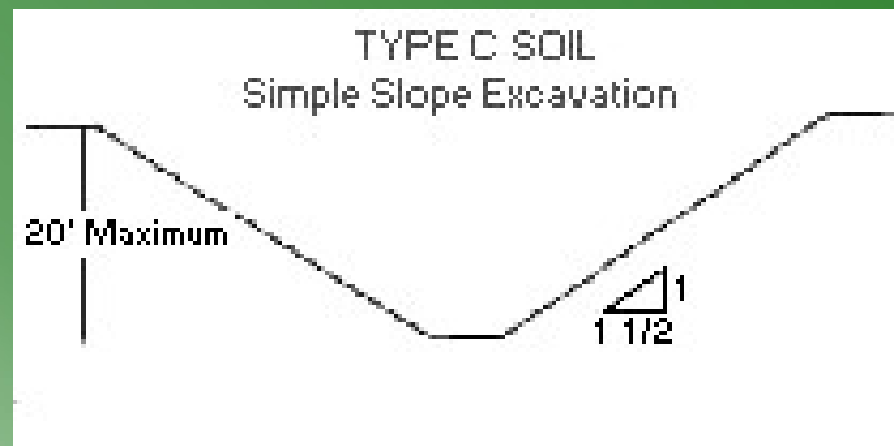
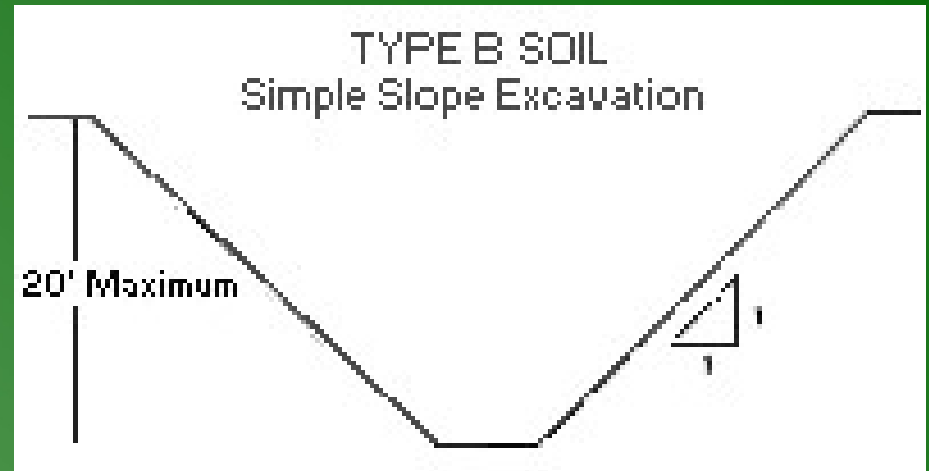
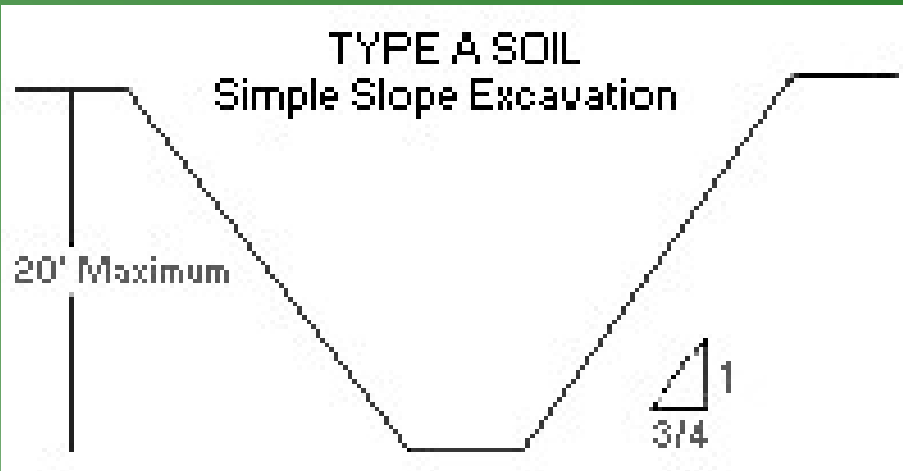

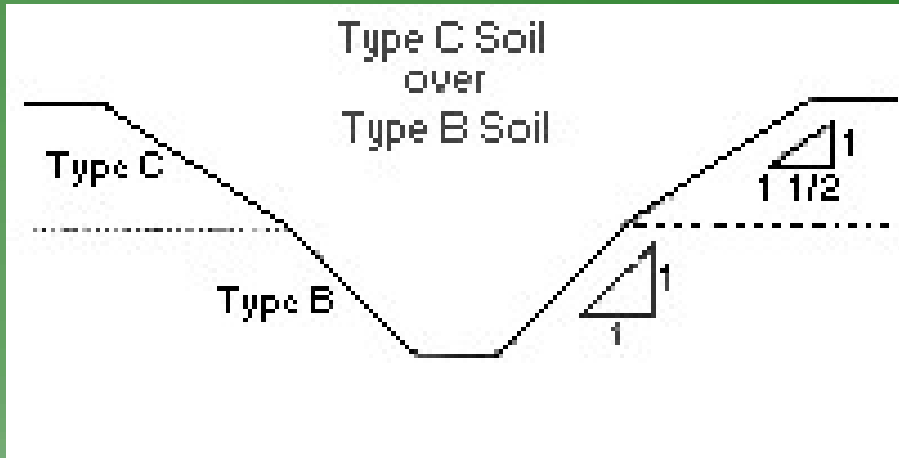
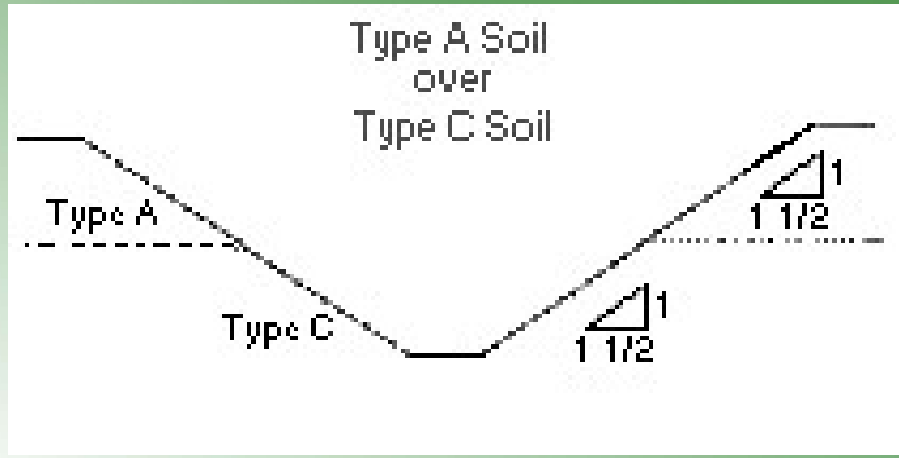
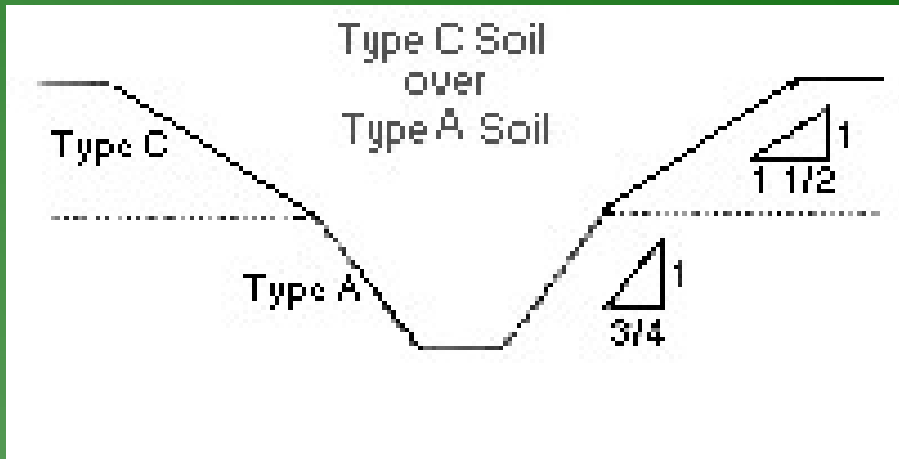
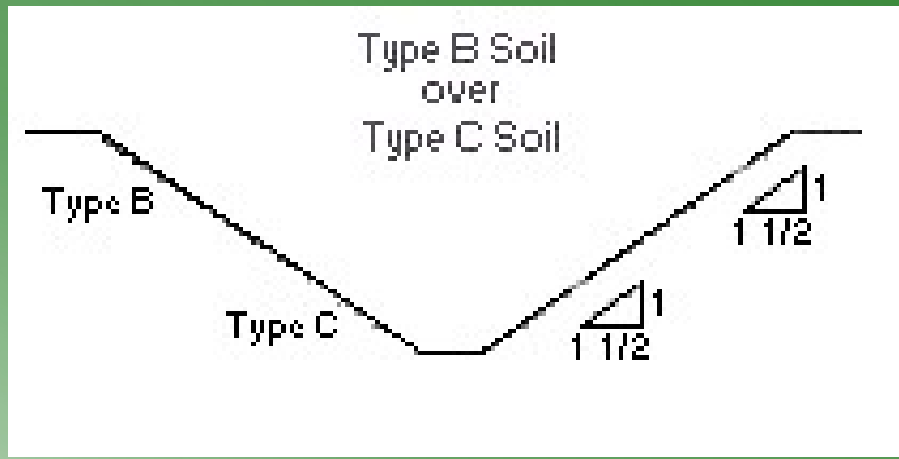
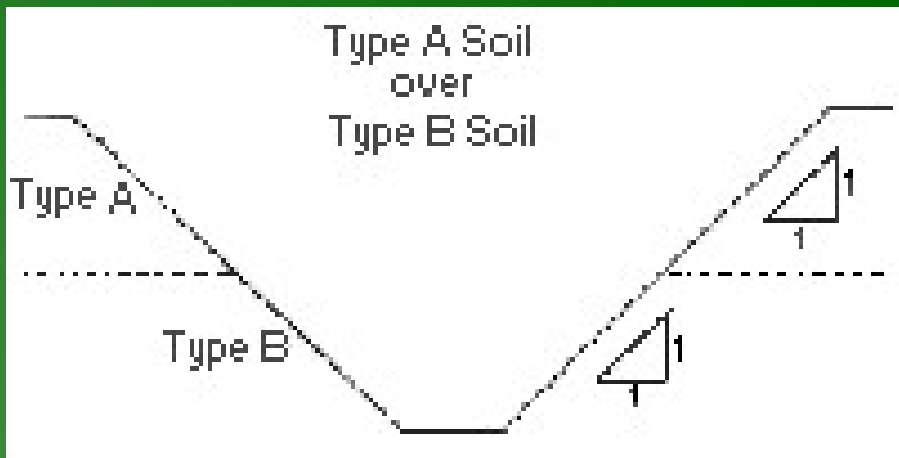
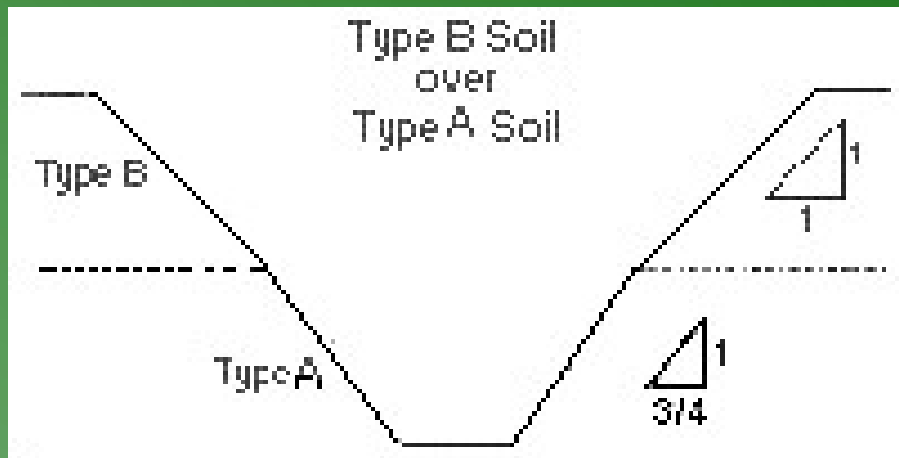

TYPE B SOIL
Single Bench Excavation
[Permitted in cohesive soil only]

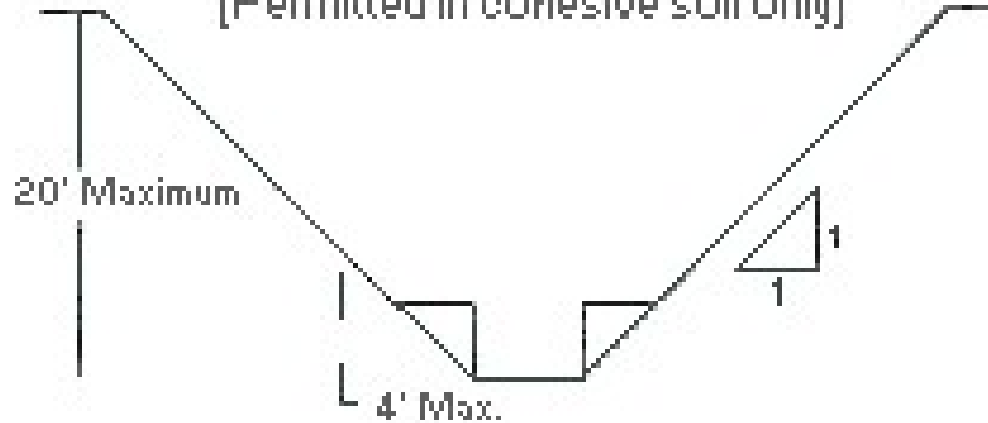

TYPE B SOIL
Multiple Bench Excavation
[Permitted in cohesive soil only]

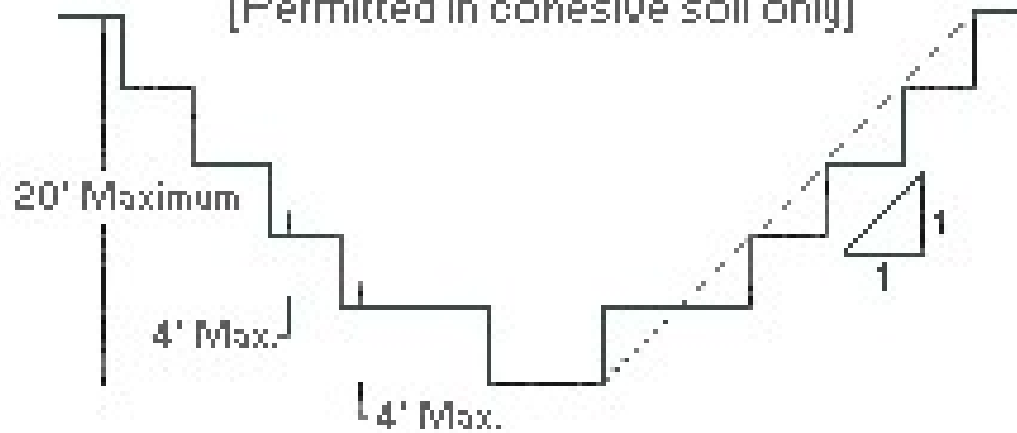

Temporary Spoil

- Temporary spoil must be placed no closer than 2 ft (0.61 m) from the surface edge of the excavation, measured from the nearest base of the spoil to the cut.
- *This distance should not be measured from the crown of the spoil deposit.*
- Ensures that loose rock or soil from the temporary spoil will not fall on employees in the trench.



Temporary Spoil

- Spoil should be placed so that it channels rainwater and other run-off water away from the excavation.
- Spoil should be placed so that it cannot accidentally run, slide, or fall back into the excavation.

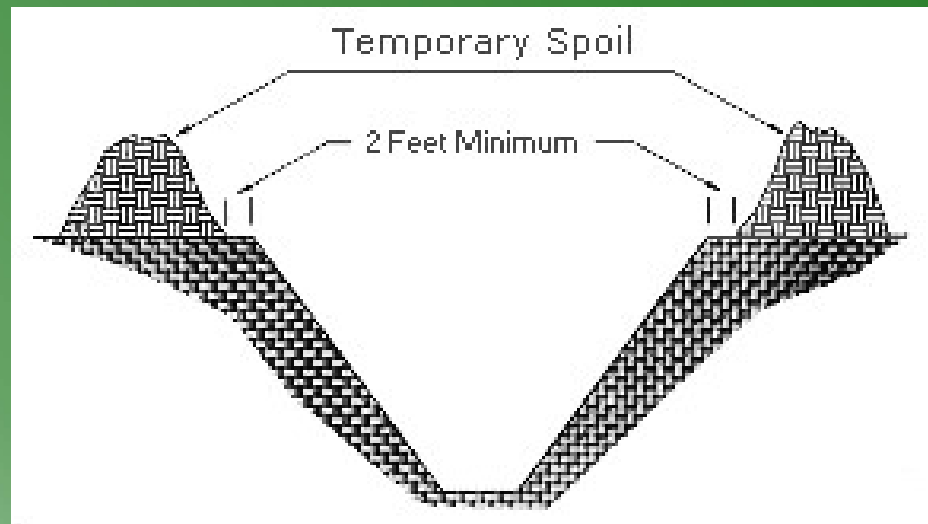



The

End